

TỔNG CÔNG TY ĐIỆN LỰC MIỀN BẮC
TRƯỜNG CAO ĐẲNG ĐIỆN LỰC MIỀN BẮC



EVN NPC
NEPC

GIÁO TRÌNH
TIẾNG ANH CHUYÊN NGÀNH

**NGÀNH/NGHỀ: QUẢN LÝ VẬN HÀNH, SỬA CHỮA ĐƯỜNG
DÂY VÀ TRẠM BIẾN ÁP CÓ ĐIỆN ÁP 110KV TRỞ XUỐNG**

TRÌNH ĐỘ: TRUNG CẤP

*(Ban hành kèm theo Quyết định số /QĐ-NEPC ngày .../.../2020
của Hiệu trưởng Trường Cao đẳng Điện lực miền Bắc)*

Hà Nội, năm 2020

TUYÊN BỐ BẢN QUYỀN

Tài liệu này thuộc loại sách giáo trình nên các nguồn thông tin có thể thể được phép dùng nguyên bản hoặc trích dùng cho các mục đích về đào tạo và tham khảo.

Mọi mục đích khác mang tính lệch lạc hoặc sử dụng với mục đích kinh doanh thiếu lành mạnh sẽ bị nghiêm cấm.

LỜI NÓI ĐẦU

Trong những năm gần đây tiếng Anh đã dần dần trở thành một ngoại ngữ thông dụng ở Việt Nam. Ngoài phạm vi giao tiếp thông thường, như thương mại, du lịch, hội thảo tại các hội nghị quốc tế và trong nước..., tiếng Anh còn là một phương tiện để giúp các cán bộ khoa học kỹ thuật, học sinh-sinh viên nước ta tiếp cận với các tài liệu, các bản vẽ, bản thiết kế cho từng ngành chuyên môn thuộc các lĩnh vực khoa học - kỹ thuật.

Giáo trình **Tiếng Anh chuyên ngành điện** là một thử nghiệm nhằm giúp học sinh-sinh viên đi sâu tìm hiểu các lĩnh vực nói trên thông qua tiếng Anh.

Tài liệu này biên soạn dành cho học sinh-sinh viên đã học qua một chương trình Tiếng Anh, khi đã nắm vững ngữ pháp tiếng Anh cơ bản cùng với vốn từ vựng khoảng 800 từ thông dụng; tức là đã học xong chương trình A hoặc B tiếng Anh hệ Tại chức do Bộ Giáo dục và Đào tạo nước Cộng hoà xã hội chủ nghĩa Việt Nam quy định, hoặc đã được theo học từ 60-80 giờ lên trên lớp. Giáo trình **Tiếng Anh chuyên ngành điện** được biên soạn để giảng dạy từ 30-45 giờ trên lớp dưới sự hướng dẫn của giáo viên. Giáo trình này cũng rất có ích đối với người học tiếng Anh muốn tự học để đọc hiểu tài liệu tiếng Anh, sau khi đã được học tiếng Anh ở trình độ như đã nói ở trên.

Giáo trình gồm hai phần chính:

- **Phần thứ nhất (English for Technical Students)**: là những bài học tiếng Anh chuyên ngành điện có kèm theo hệ thống bài tập để củng cố vốn ngữ pháp và kỹ năng đọc hiểu.

- **Phần thứ hai (Oxford English for Electrical and Mechanical Engineering)**: gồm các bài học chuyên ngành nhằm củng cố và mở rộng các kỹ năng nói, đọc và viết; đồng thời nâng cao vốn hiểu biết về hệ thống ngữ pháp tiếng Anh được dùng trong văn phong khoa học.

Do thời gian có hạn, cũng như tài liệu được tuyển chọn và chú giải lần đầu, nên không thể tránh khỏi những sai sót nhất định, chúng tôi mong nhận được các ý kiến đóng góp của người học và những người sử dụng giáo trình này.

Cuối cùng, chúng tôi xin chúc người học thành công!

Tập thể giảng viên

KHOA KHOA HỌC CƠ BẢN

MỤC LỤC

ĐỀ MỤC	TRANG
Unit 1: Getting started	7
1. Vocabulary	8
2. What do you know?	9
3. The one at the top	13
4. What shape is it?	15
Unit 2: What are these objects called?	17
1. Vocabulary	18
2. Check that the switches are on!	19
3. Move it forwards	21
4. They have no covers	24
5. Bring me the hammer!	27
Unit 3: First, Mark a hole!	32
1. Vocabulary	33
2. First, you mark the hole!	34
3. Switch off before you touch that wire	36
4. The current is stopped by pressing this switch	38
5. Reading comprehension	42
Unit 4: Safety rules	45
1. Vocabulary	46
2. You might get a shock	47
3. You must never smoke near petrol	50
4. Tools that are damaged are dangerous	53
5. Add, subtract, multiply, divide	56
6. Reading comprehension	58
Unit 5: Circuit elements	61
1. Vocabulary	62
2. Reading comprehension	63
3. Language study	66
4. Writing	67
Unit 6: The electric motor	69
1. Vocabulary	70
2. Reading comprehension	71
3. Language study	74
4. Writing	75

Unit 7: Transformers	77
1. Vocabulary	78
2. Reading comprehension	79
3. Language study	81
4. Writing	82
Unit 8: Reclosers	86
1. Vocabulary	87
2. Reading comprehension	88
3. Language study	89
4. Writing	92
Unit 9: Safety at work	95
1. Vocabulary	96
2. Reading comprehension [1]	97
3. Language study	98
4. Writing	100
5. Reading comprehension [1]	102
Tóm tắt ngữ pháp	105
Tài liệu tham khảo	108

GIÁO TRÌNH MÔN HỌC

Tên môn học: TIẾNG ANH CHUYÊN NGÀNH ĐIỆN

Mã môn học: MH 08

VỊ TRÍ, TÍNH CHẤT CỦA MÔN HỌC:

- Vị trí: Môn học được bố trí sau khi sinh viên học xong chương trình A và B ngữ pháp tiếng Anh cơ bản cùng với vốn từ vựng khoảng 800 từ thông dụng.

- Tính chất: Là môn học ngoại ngữ chuyên ngành bắt buộc.

MỤC TIÊU CỦA MÔN HỌC:

Học xong môn học này, người học có khả năng:

- Về kiến thức: Trình bày được các từ vựng, cấu trúc cơ bản của tiếng Anh chuyên ngành điện: từ vựng; tên thiết bị, máy móc; nội quy, quy định...;

- Về kỹ năng: Đọc hiểu được các tài liệu, hình vẽ, sơ đồ, bảng biểu; Nghe, nói và viết được các đoạn văn theo chủ đề;

- Về năng lực tự chủ và trách nhiệm: Làm việc độc lập, tự học để đọc hiểu các tài liệu tiếng Anh chuyên sâu chuyên ngành điện.

NỘI DUNG MÔN HỌC:

STT	Tên bài	Thời gian			
		Tổng số	Lý thuyết	Bài tập	Kiểm tra (*)
1	Getting started	5	2	3	
2	What are these objects called?	5	2	3	
3	First, Mark a hole	4	2	2	1
4	Safety rules	5	2	3	
6	Circuit elements	4	2	2	
7	The Electric motor	4	2	2	1
8	Transformers	5	2	3	
10	Reclosers	6	2	4	
11	Safety at work	4	2	2	1
	Cộng	45	18	24	3

ENGLISH FOR TECHNICAL STUDENTS

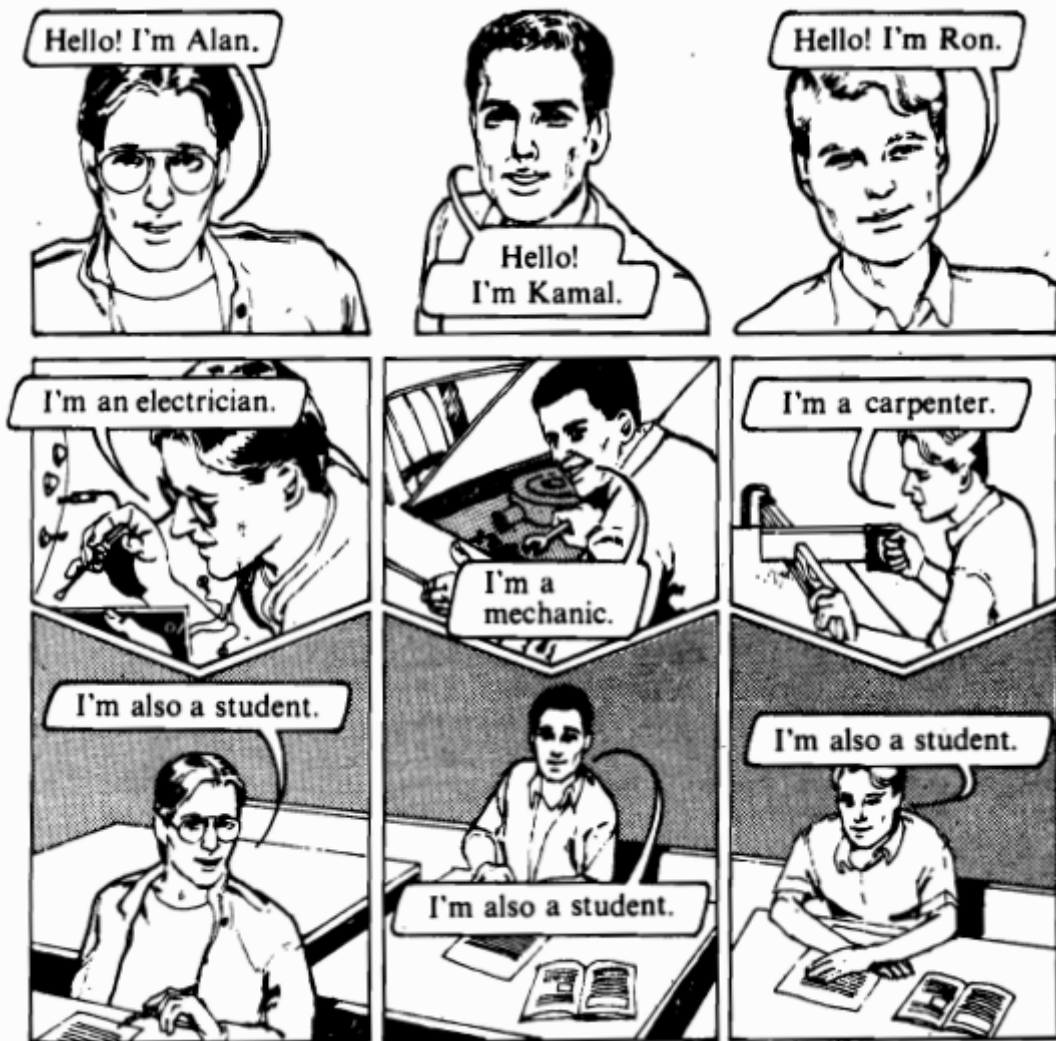

Unit 1: Getting started

Mục tiêu

Học xong bài học này, người học có khả năng:

- Đọc được từ vựng chỉ tên thiết bị, tên máy móc;
- Sử dụng cấu trúc câu hỏi "what", "where", "how long/how high": đặt câu hỏi và trả lời câu hỏi;
- Viết, nói những lời mô tả đơn giản về các trang thiết bị điện;
- Sử dụng giới từ chỉ vị trí "at, on, under, in, above...";
- Đọc hiểu, xác định được vị trí của các đồ vật và trang thiết bị;
- Sử dụng tính từ miêu tả hình dáng của vật, đồ vật: đặt câu hỏi và trả lời.



Nội dung

1. VOCABULARY:

base /beɪs/	(n)	chân đế	plug /plʌg/	(n)	phích cắm
blade /bleɪd/	(n)	lưỡi, cánh	pull /pʊl/	(v)	kéo lại
button /'bʌtn/	(n)	nút bấm	screw /skru:/	(n)	đinh vít
caution /'kɔ:ʃn/	(n)	cẩn thận để tránh lỗi	screwdriver /'skru:,draɪvə/	(n)	tuốc nơ vít
circular /'sə:kjʊlə/	(adj)	có hình tròn	sequence /'si:kwəns/	(n)	chuỗi
description /dɪs'krɪpʃn/	(n)	sự mô tả	shape /ʃeɪp/	(n)	hình dạng
diagram /'daɪəgræm/	(n)	biểu đồ	socket /'sɒkɪt/	(n)	ổ cắm
fan /fæn/	(n)	cái quạt	square /skweə/	(n)	hình vuông
guard /gɑ:d/	(n)	lông quạt	steel /sti:l/	(n)	thép
instruction /ɪn'strʌkʃn/	(n)	lời chỉ dẫn	tighten /'taɪtn/	(v)	thít chặt
label /'leɪbl/	(n)	nhãn	touch /tʌtʃ/	(v)	đụng, chạm
loose /lu:s/	(adj)	lỏng, lỏng lẻo	warning /'wɔ:nɪŋ/	(n)	lời cảnh cáo
plastic /'plæstɪk/	(n)	chất dẻo	wide /waɪd/	(adj)	rộng

2. "WHAT DO YOU KNOW?"

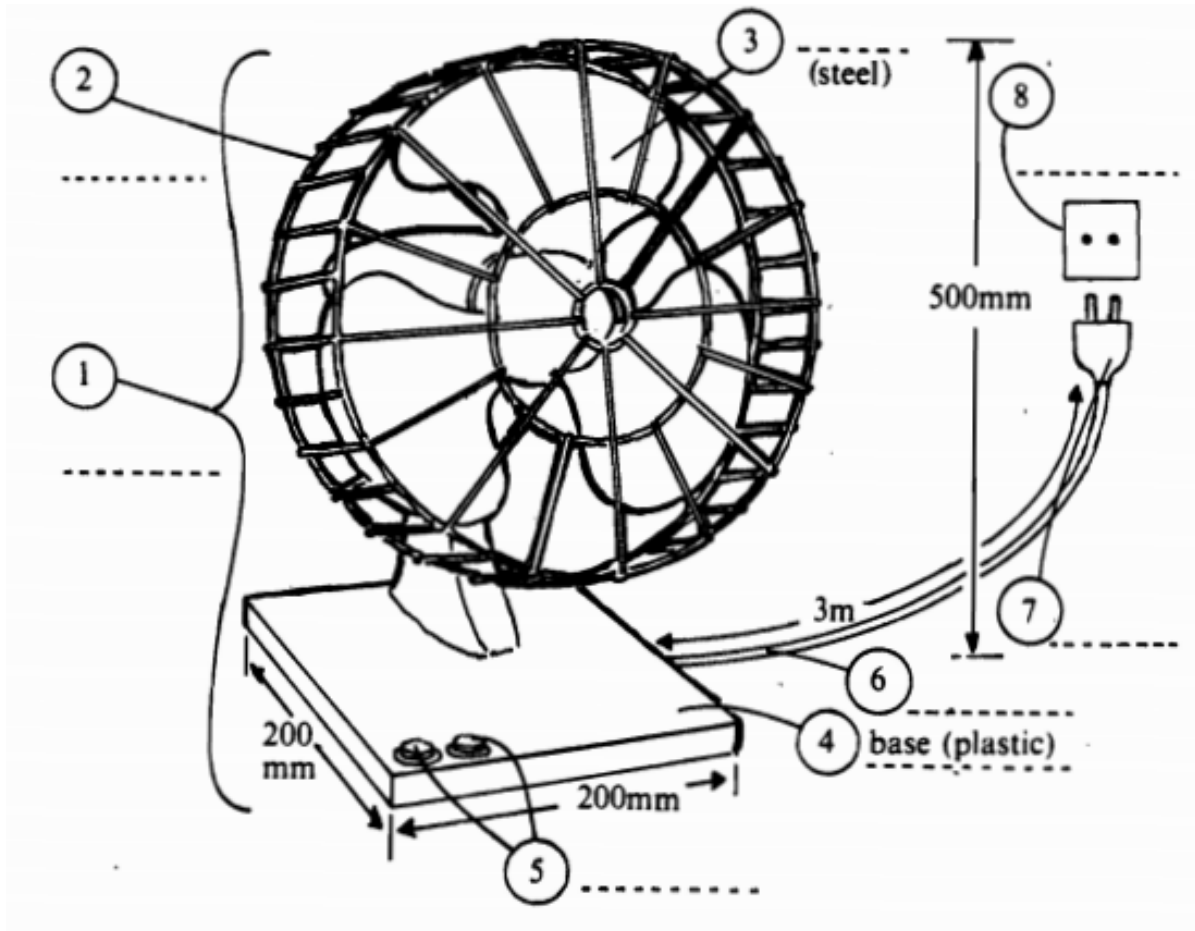

2.1 Complete the labels:

Example: (1) - fan → This is a fan. It's number 1.

2.2 Answer these questions:

Example: (a) What are these called? **They're called bases.**

- What are these called?
- How high is the fan?
- How wide is the base of the fan?
- What shape is the plug?
- What shape is the socket?
- What shape is the base?
- What is the length of the wire?
- How many buttons does the fan have?

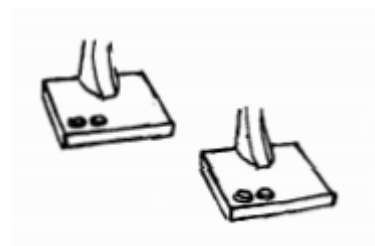

- (i) How many blades does the fan have?
- (j) Where is the ON/OFF button? (Answer: "left")
- (k) Where is the FAST/SLOW button? (Answer: "right")
- (l) What are the blades made of?
- (m) What is the base made of?
- (n) Is the plug in the socket?
- (o) Why are the blades made of steel?

2.3 Complete this:

Example: "In this diagram, *there is* a fan"

In this diagram, a fan. The fan three blades and a guard. The blades steel. There two buttons on base fan. The button on the is the ON/OFF button, and the one is the FAST/SLOW button. The fan a wire and a plug. socket on wall. The plug is in the socket.

2.4 Make a similar description of this diagram:

Begin: "In this diagram, there is a fan. The fan has"

.....

.....

.....

.....

.....

.....

.....

.....

.....

.....

.....

.....

.....

.....

.....

.....

.....

.....

.....

.....

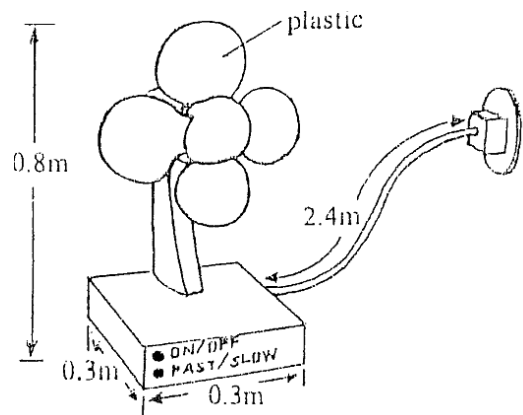

2.5 Make questions about the diagram in Part 2.4:

Example: (a) How high is the fan?

- | | |
|-----------|--------------------------------------|
| (a) | It's 0.8m high. |
| (b) | It's about 2.5m long. |
| (c) | It's circular. |
| (d) | They're made of plastic. |
| (e) | It's above the FAST/SLOW button. |
| (f) | Because plastic is a tough material. |
| (g) | It's below the ON/OFF button. |
| (h) | They're called blades. |
| (i) | It's 0.3m wide. |
| (j) | It has two. |
| (k) | They're square. |
| (l) | It has four. |
| (m) | It's in the socket. |

2.6 Put these instructions into the best sequence:

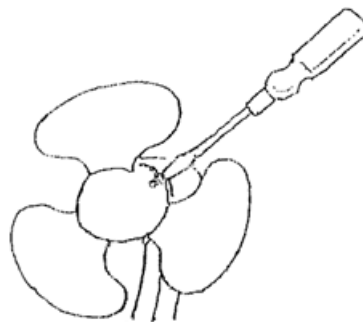

- (1) Open the guard of the fan.
- (2) Switch the fan on.
- (3) Tighten the screw behind the fan blades.
- (4) Caution: do not touch the blades of the fan.
- (5) Switch the fan off.
- (6) Put the plug into the socket.

- (7) Pull the plug out.
- (8) Close the guard of the fan.

2.7 Where is it?

Kamal, Ron and Alan live together in this house.

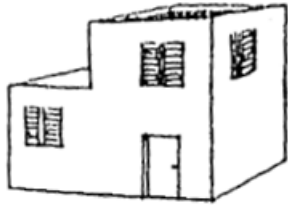



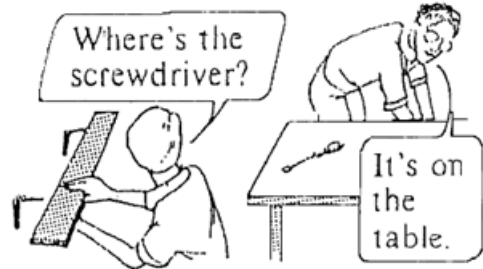

Ron and Alan often repair the house.

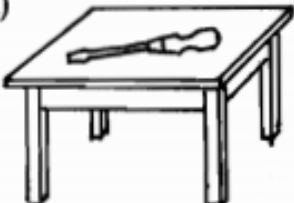
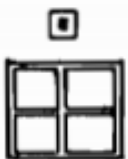

- * **Repeat:** A: Where's the screwdriver?
B: It's on the table.

* **Make sentences:**

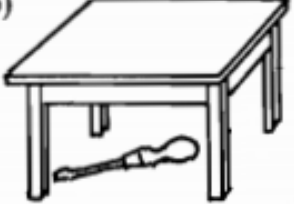
Example: (a) The screwdriver is on the table.

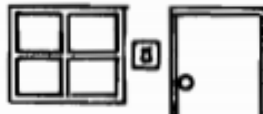
The screwdriver is	The switch is
(a)  on the table	(d)  above the window (f)  beside the window
(b)  under the table	(e)  below the window
(c)  in the box	(g)  between the window and the door

3. "THE ONE AT THE TOP"

3.1 Study with "at, on, under, in, above..."

* Alan is repairing the lights.

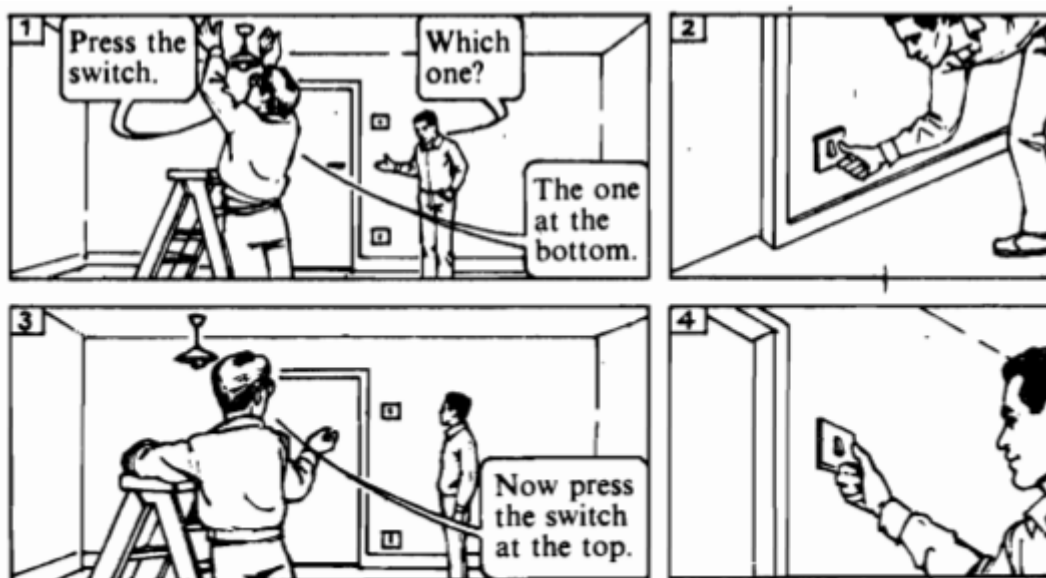

* Repeat:

A: Press the switch.

B: Which one?

A: The one at the bottom... Now press the switch at the top.

* Study this:

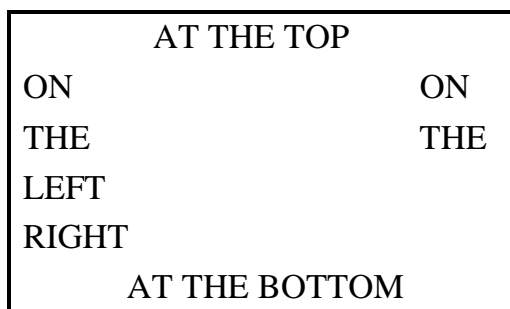

3.2 Match the words with the numbers:

Example: (a) on the left of the wall – **number 4**

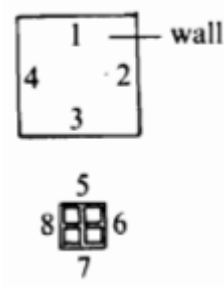

- (a) on the left of the wall
- (b) at the top of the wall
- (c) above the window
- (d) to the left of the window
- (e) on the right of the wall
- (f) to the right of the window
- (g) at the bottom of the wall
- (h) below the window

3.3 Match the sentences with the numbers in the pictures:

Example: (a) Please press the switch to the right of the window - **number 4**

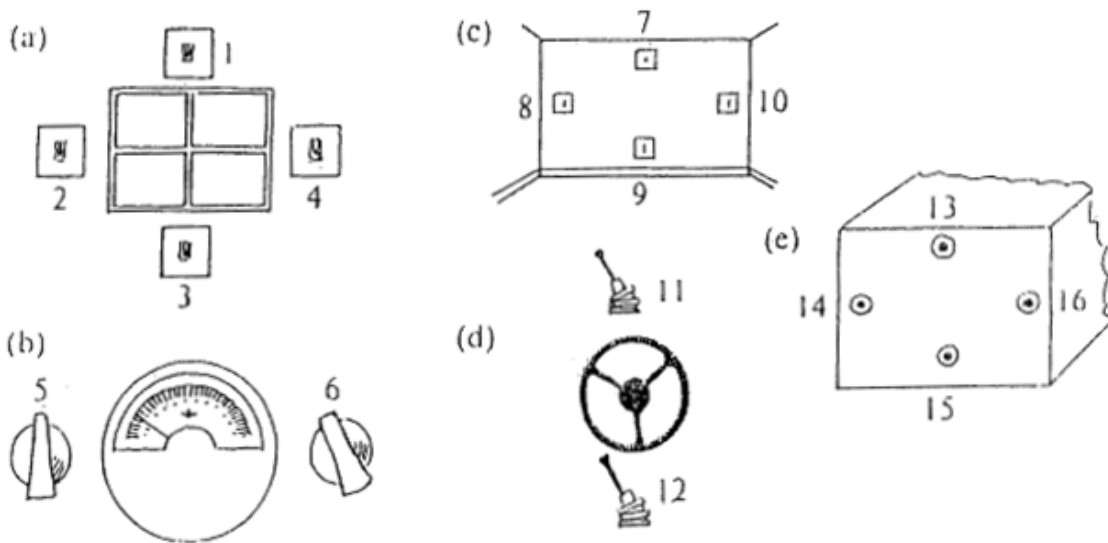

- (a) There's no light in here. Please press the switch to the right of the window.
- (b) Please pull the lever below the wheel.
- (c) Could you press the ON button, please? That's the button on the right.
- (d) Turn the knob to the left of the dial.
- (e) Could you press the switch above the window, please?
- (f) Use the socket at the bottom. It has 110 volts.
- (g) Press the button at the top.
- (h) Use the socket on the left.
- (i) Could you now turn the knob to the right of the dial, please?
- (j) Now pull the lever above the wheel.
- (k) Press the switch to the left of the window.
- (l) Now please put the plug into the socket on the right.

- (m) Please use the socket at the top of the wall.
- (n) Now press the OFF button. That's the button on the left.
- (o) And now press the button at the bottom.
- (p) Please press the switch below the window.

4. "WHAT SHAPE IS IT?"

Kamal is repairing a hole in the car.

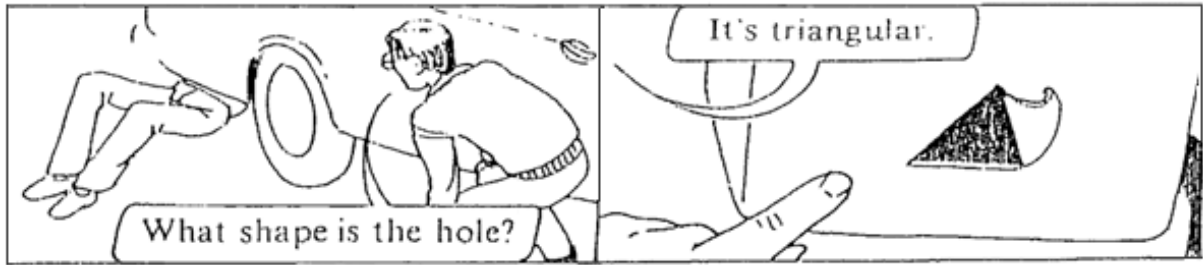

*** Repeat:**

A: What shape is the hole?

B: It's triangular.

4.1 Read this:

- The door is **rectangular**.
- The plug is **triangular**.
- The window is **square**.
- The wheel is **circular**.
- The wheel is **round**.

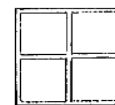
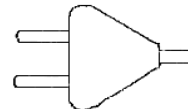
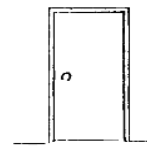

4.2 Make sentences:

Example: (a) This ruler is rectangular.

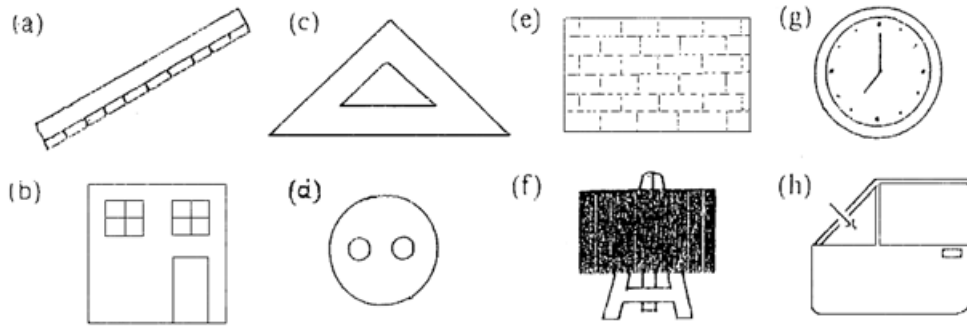

4.3 Match the warnings with the numbers in the picture:

Example: (a) Be careful! There's some water under the wire - **number 6**.

- (a) Be careful! There's some water under the wire.
- (b) Don't run here!
- (c) Look out! There's some oil on the floor.
- (d) Don't touch the blades!
- (e) Be careful! The guard is open. Close it.
- (f) Tighten those screws. They're loose.

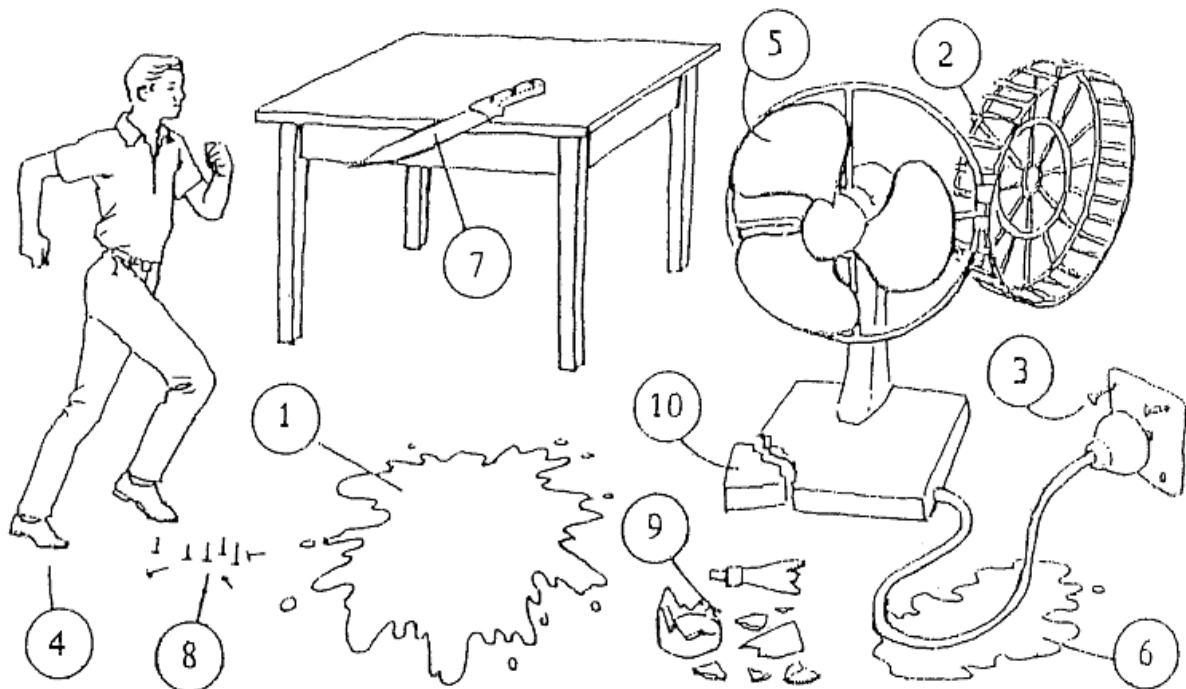

Unit 2: What are these objects called?

Mục tiêu

Học xong bài học này, người học có khả năng:

- Đọc được từ vựng tiếng Anh chuyên ngành trong bài học;
- Sử dụng cấu trúc Check that: trả lời và viết lại câu;
- Sử dụng các cặp động từ mang nghĩa tương đương;
- Tìm hiểu một số động từ nguyên thể và cấu trúc câu mệnh lệnh;
- Sử dụng các trạng từ "clockwise, upwards, forwards, inwards....";
- Gọi tên và mô tả hoạt động của một số dụng cụ;
- Sử dụng cặp tính từ "safe" và "dangerous";
- Tìm hiểu cách sử dụng cặp từ "each" và "all together";
- Phân biệt hai động từ "bring" và "give".



Nội dung

1. VOCABULARY:

anti-clockwise /ænti'klɔ:kwaiz/	(adj, adv)	ngược chiều kim đồng hồ	insert /'insə:t/	(v)	gài vào
apart /ə'pɑ:t/	(adv)	tách rời	italic /i'tælik/	(adj)	chữ in nghiêng
backwards /'bækwədz/	(adv)	ngược phía sau	inwards /'inwədz/	(adv)	hướng vào phía trong
bend /bentf/	(v)	uốn cong	lever /'li:və/	(n)	đòn bẩy, tay đòn
belt /belt/	(n)	dây lưng	loosen /'lu:sn/	(v)	nới lỏng
bottom /'bɒtəm/	(n)	đáy	(the) mains /meinz/	(n)	nguồn
bulb /bʌlb/	(n)	bóng đèn	nut /nʌt/	(n)	đai ốc
bucket /'bʌkit/	(n)	thùng, xô	outwards /'aʊtwɔ:dz/	(adv)	hướng ra phía ngoài
chisel /'tʃizl/	(n)	cái đục	passage /'pæsɪdʒ/	(n)	đoạn
clockwise /'klɔ:kwaiz/	(adv, adj)	theo chiều kim đồng hồ	pliers /'plaiəz/	(n)	cái kìm
cool /ku:l/	(v)	làm cho mát	press /pres/	(n)	sự nén, ép
cover /'kʌvə/	(n)	cái vỏ, bìa	pump /pʌmp/	(n)	cái bơm
downwards /'daʊnwədz/	(adv)	xuống phía dưới	push /puʃ/	(v)	đẩy
drill /drɪl/	(v)	khoan	replace /ri'pleis/	(v)	đặt trở lại vị trí cũ
engine /'endʒɪn/	(n)	động cơ	remove /ri'mu:v/	(v)	đưa ra khỏi
examine /'ɪg'zæmɪn/	(v)	khám xét	rotate /rou'teɪt/	(v)	quay xung quanh
forwards /'fɔ:wədz/	(adv)	tiến về phía trước	spark plug /'spɑ:k'plʌg/	(n)	bu-gi
gap /gæp/	(n)	khoảng cách	switch /swɪtʃ/	(n)	công tắc
gauge /geɪdʒ/	(n)	cỡ, hạn, độ; cái dưỡng	switch off /,swɪtʃ'ɔ:f/	(v)	ngắt dòng điện
goggles /'gɒglz/	(n)	kính bảo hộ	switch on /,swɪtʃ'ɔ:n/	(v)	đóng dòng điện
hammer /'hæmə/	(n)	cái búa	tank /tæŋk/	(n)	thùng chứa
handle /'hændl/	(n)	tay cầm	tool /tu:l/	(n)	dụng cụ

hook /huk/	(n)	cái móc	torch /'tɔ :tʃ/	(n)	đèn pin
hose /houz/	(n)	ống, vòi	turn /tɜ:n/	(n)	quay, vòng quay

2. "CHECK THAT THE SWITCH IS ON"

There is a power cut in the house. All the electricity is off. Ron, Alan and Kamal can't see.



2.1 Answer the questions:

Examples:

(a) Check that the switches are on. **Yes, they're on.**

(b) Check that the door is closed. **No, it's not closed. It's open.**

(c) Check that the windows are open.

(d) Check that the TV is off.

(e) Check that the shelf is straight.

(f) Check that the tank is full.

(g) Check that the car is clean.

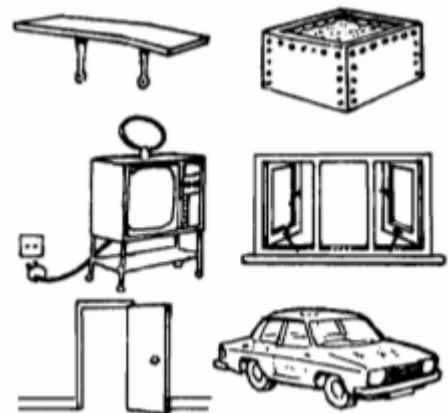

2.2 Put these instructions into the correct order:

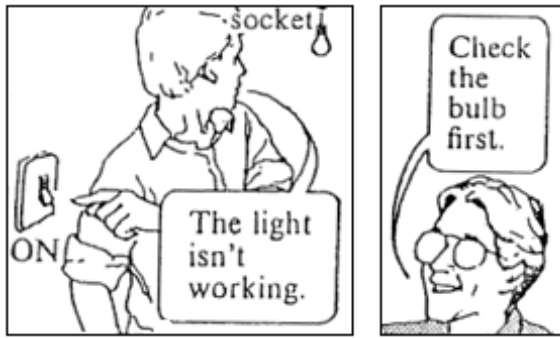

*** How to check the light bulb**

- Take it out of the socket.
- Turn the bulb anti-clockwise.
- Switch off the power.
- Look at it.
- Test it.

**** Begin like this:**

- (1) Switch off the power.
- (2)
- (3)
- (4)
- (5)

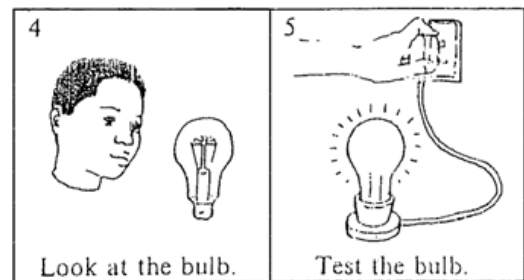

***** What do these instructions mean? Get your answers from Part 2.2 (**):**

Example: (a) *Examine* the bulb. = **Look at** the bulb.

- (a) Examine the bulb.
- (b) Remove the bulb.
- (c) Rotate the bulb.

2.3 Change the questions into instructions. (Use the word CHECK):

NOTICE. Check these things before you leave the workshop.

- (a) Are all the machines off?
- (b) Is the floor clean?
- (c) Are the tools in the boxes?
- (d) Are the fire buckets full?
- (e) Are the goggles in the store room?
- (f) Is the store room closed?

Example:

- (a) Are all the machines off?
→ **Check that all the machines are off.**

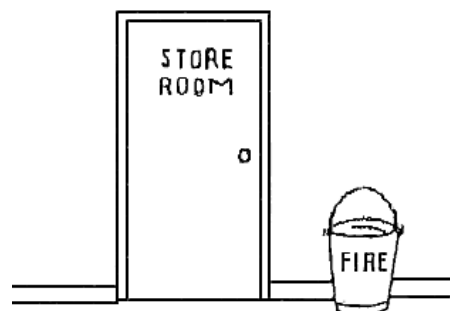

- (g) Are the windows and doors closed?
- (h) Is the main switch off?

3. "MOVE IT FORWARDS"

Kamal is giving instructions in the workshop.

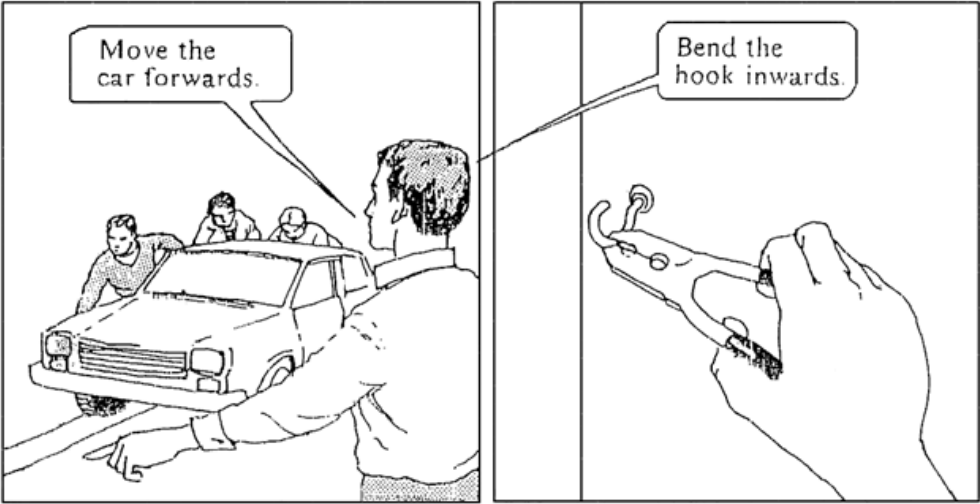

3.1 Study this: Match these words with pictures (f-j)

anti-clockwise; downwards; outwards; backwards; to the left.

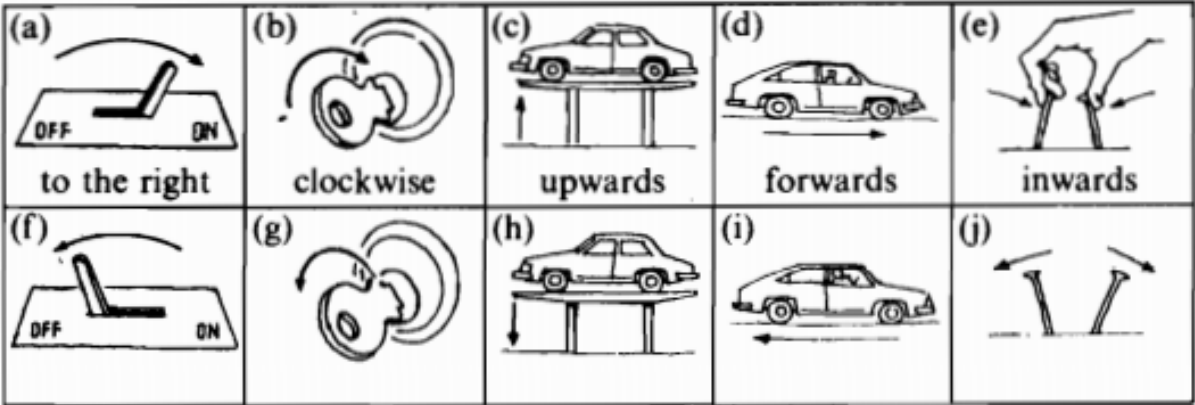

3.2 Make instructions: Look at the pictures in Part 3.1

Example: (a) Push the lever to the right.

- | | |
|---|-----------------|
| (a) Push the lever to the right. | (f) Push |
| (b) Turn | (g) Turn |
| (c) Move | (h) Move |
| (d) Drive | (i) Drive |
| (e) Bend | (j) Bend |

*** Make instructions. Begin "Don't" :**

Example: (a) **Don't** turn the bulb clockwise.

- | | |
|------------------------|-------------------------|
| (a) bulb | Turn it anti-clockwise. |
| (b) lever | Push it forwards. |
| (c) hook | Bend it inwards. |
| (d) car | Turn it to the right. |
| (e) handle | Pull it downwards. |
| (f) wheel | Turn it clockwise. |

*** Match the instructions on the left with the ones on the right:**

Example: (a) - (5) Tighten the screw. Turn it clockwise.

- | | |
|---------------------------|------------------------------|
| (a) Tighten the screw. | 1 Write from left to right. |
| (b) Switch off the power. | 2 Turn it anti-clockwise. |
| (c) Write in English. | 3 Push the switch downwards. |
| (d) Loosen the nut. | 4 Push the switch upwards. |
| (e) Write in Arabic. | 5 Turn it clockwise. |
| (f) Switch on the power. | 6 Write from right to left. |

*** What are these tools called? Choose words from the list below:**

/ chisel / plane / drill / pliers / hammer / wrench /

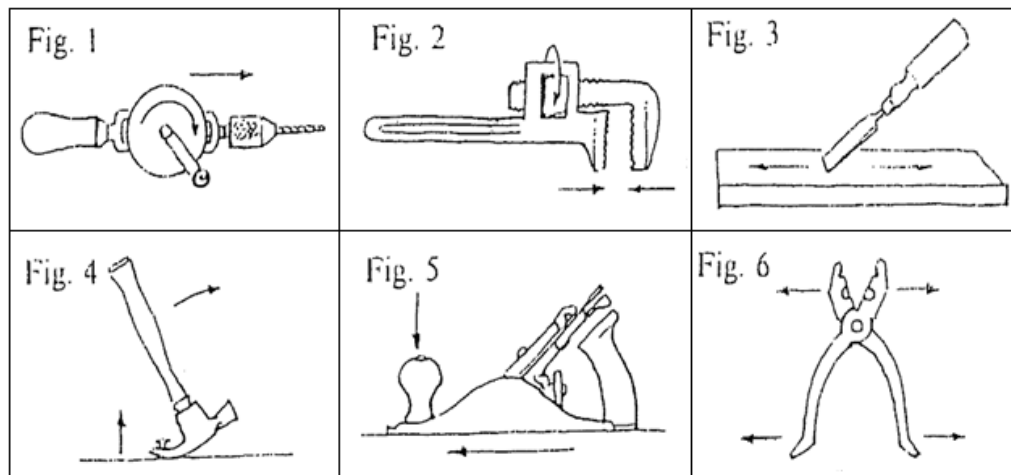

*** Match these instructions with the picture above:**

Example: (a) - Fig. 5

- (a) Press it downwards and push it forwards.
- (b) Move it forwards and backwards.
- (c) Push it forwards and rotate the handle.
- (d) Pull it upwards and towards you.
- (e) Rotate the nut and move the jaws together. (together = inwards)
- (f) Pull the handles and move the jaws apart. (apart = outwards)

4. "THEY HAVE NO COVERS"

Alan is checking the fans and switches.

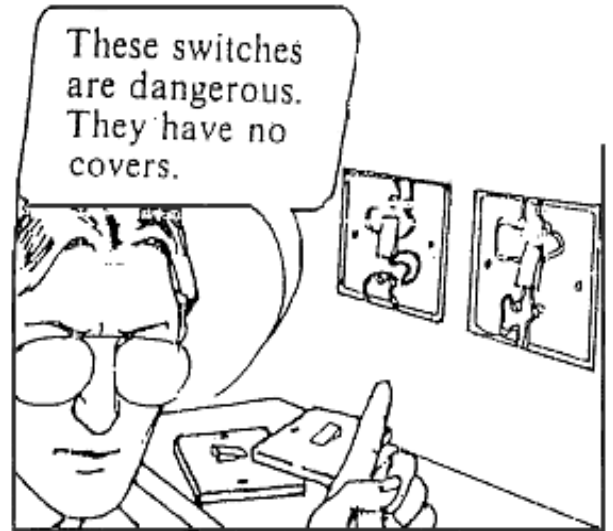

*** Repeat:**

A: This fan is dangerous. It has no guard.

These switches are dangerous. They have no covers.

4.1 Study these:

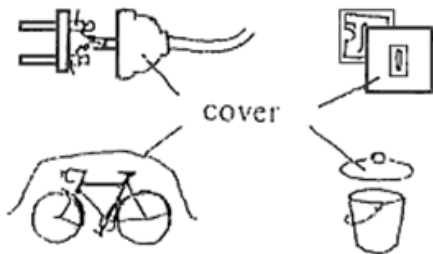

.....

.....

.....

.....

.....

.....

.....

*** Make sentences:**

Example: (a) These fans are safe. They have guards.

(b) These switches are dangerous. They have no covers.

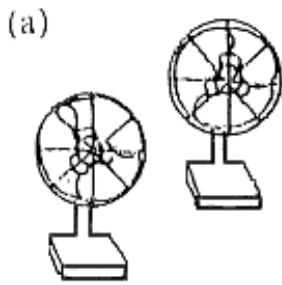

fans / guards

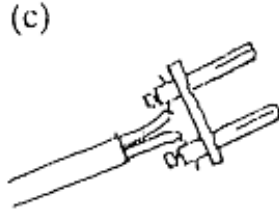

plug / cover

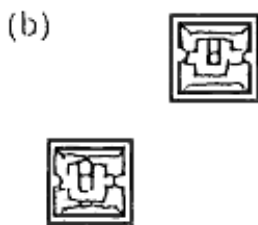
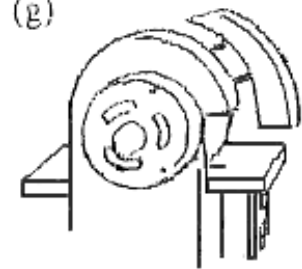
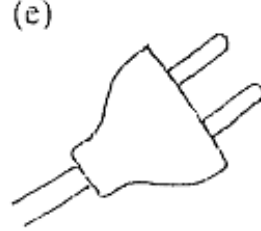

switches / covers

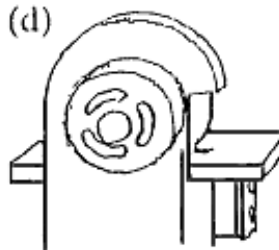

machine / guard

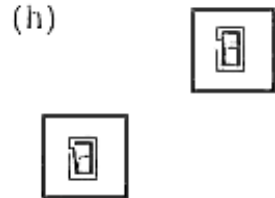
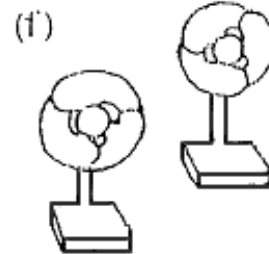

4.2 Complete the sentences:



Alan and Ron have one watch **each**. OR Alan and Ron have two watches **altogether**.

Example: (a) These ladders have 12 **rungs** all together.

(b) These tables **have** no legs.

- (a) These ladders have 12 all together.
- (b) These tables no legs.
- (c) These saws two handles
- (d) These fans three guards together.
- (e) These hammers no
- (f) These chairs have legs all
- (g) These knives have two
- (h) These men two
- (i) These fans have six blades

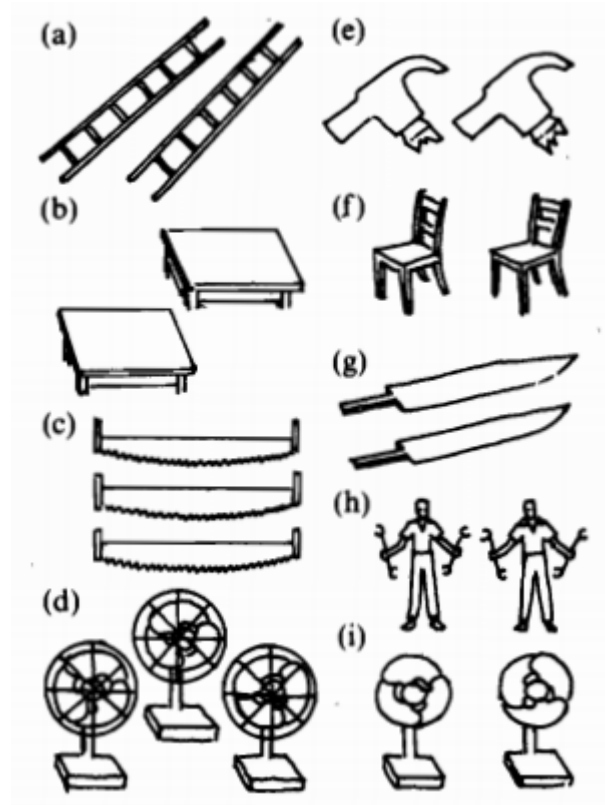

*** Make questions and answers:**

Example: (a) - A: What's wrong with the car?
 B: It has no wheels.

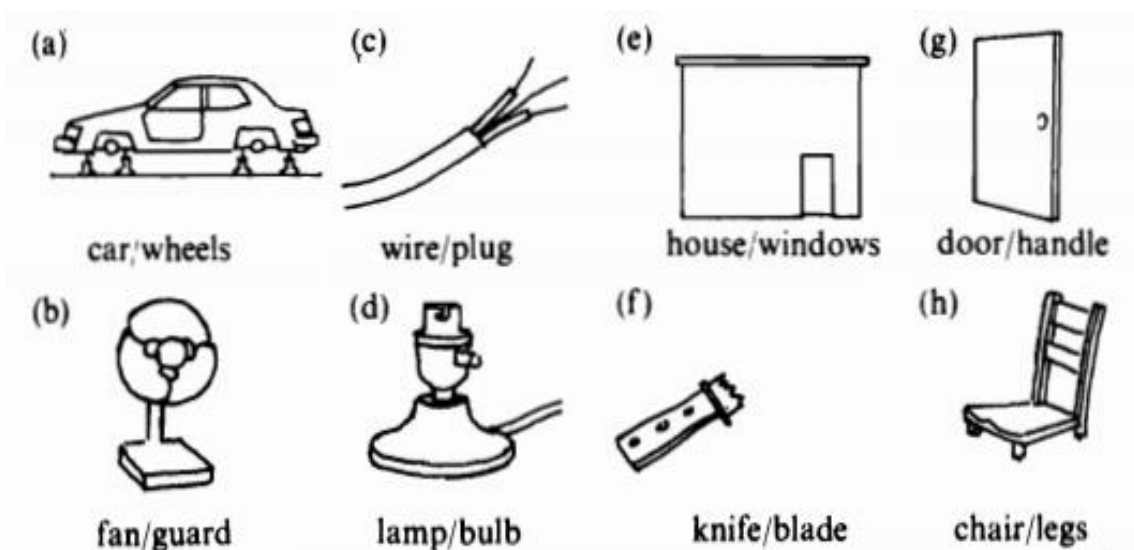

5. "BRING ME THE HAMMER!"

Ron is repairing a cabinet.

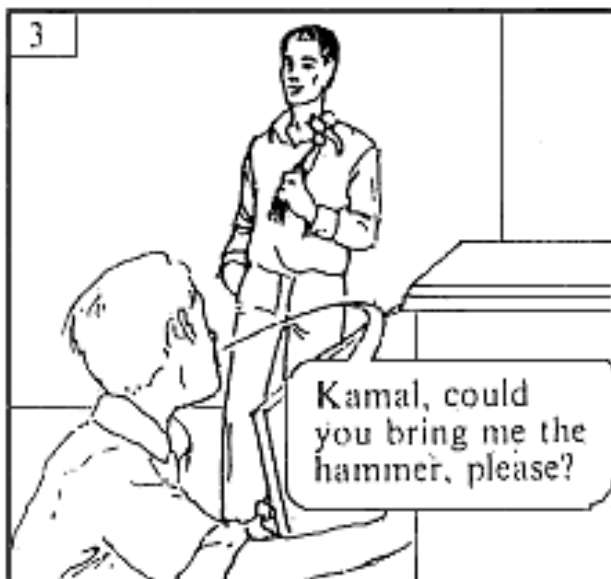
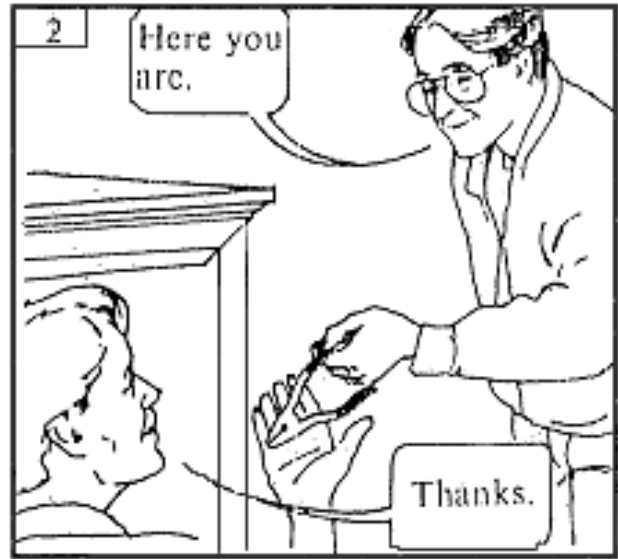

5.1 Repeat this:

- (a) Please bring me the hammer!
- (b) Could you give me the pliers, please?

5.2 Ask for objects in the classroom. Use "BRING" and "GIVE":

Example: (a) A: Could you give me the pen, please?

B: Here you are.

A: Thanks.

a pen

d ruler

g bag

b pencil

e setsquare

h chair

c eraser

f book

i box

*** What is Ron saying?**

Example: 1 Please give me the nails, Alan!

2 Could you bring me the ruler please, Kamal?

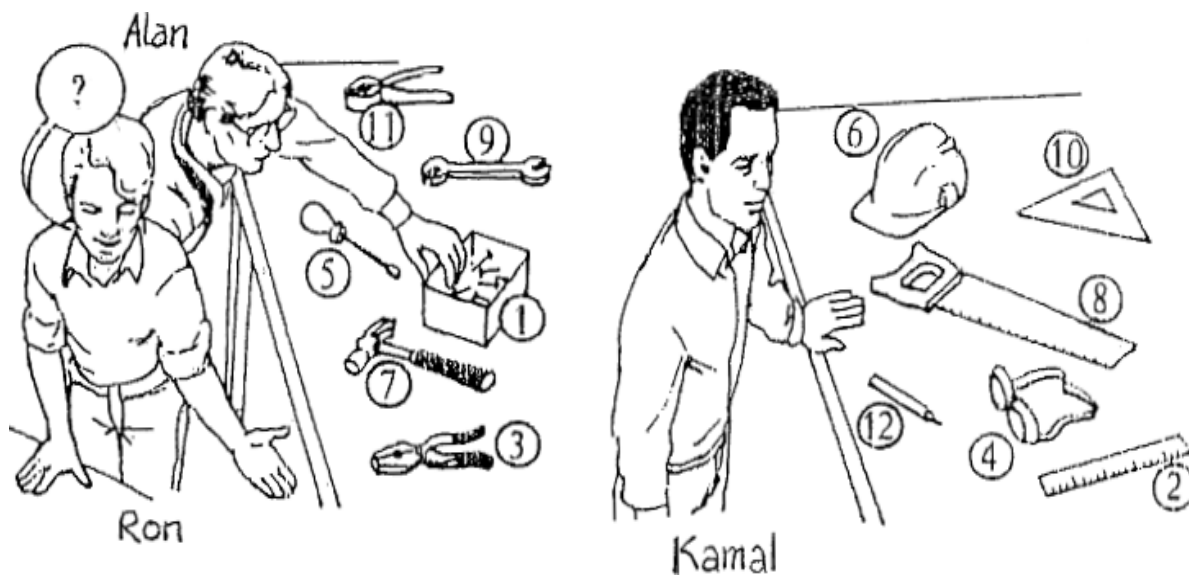

5.3 Reading comprehension: (A) AUTOMOTIVE: ELECTRICAL SYSTEM

Today's job

How to check a spark plug

- 1 Remove the cover.
- 2 Place the spanner over the spark plug.
- 3 Rotate the plug anti-clockwise until it is loose.
- 4 Remove the plug from the socket.
- 5 Examine the gap and check that it is clean.
- 6 Insert the *gauge* in the gap.
- 7 Check that the gap is between 0.65 and 1.00 mm wide.
- 8 Replace the *plug* in the socket.
- 9 Rotate the plug clockwise until it is hand-tight.
- 10 Place the spanner over the plug and give a quarter turn clockwise.
- 11 Caution: Do not over-tighten the plug.
- 12 Replace the cover.

a- What are these objects called? (Look at the words in *italic* in the passage.)

Example: (a) This is called a *spark plug*

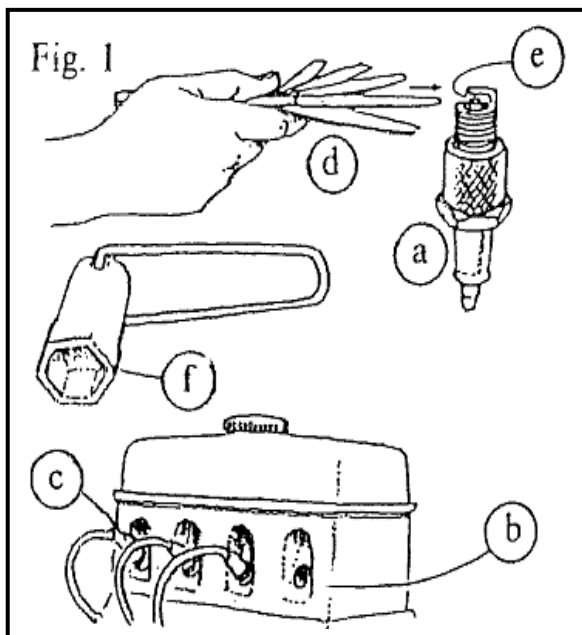

b- Are these instructions correct? (Answer YES or NO). Correct the wrong ones:

- (a) Turn the plug anti-clockwise, and tighten it.
- (b) Look at the gap and clean it.
- (c) Put the gauge into the gap and check the width.
- (d) Tighten the plug with your hand. Then use the spanner.

c- Which is the correct width of the gap? Choose (a), (b) or (c):

- (a) 0.5mm; (b) 0.85mm; (c) 1.65mm

d- What does "a quarter turn" mean? Choose (a), (b), (c), or (d):

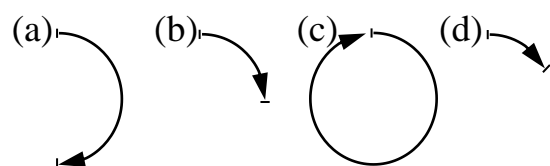

A car cooling system

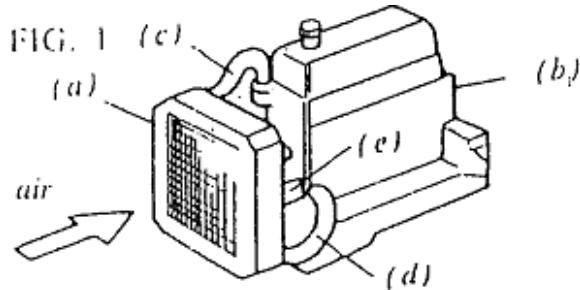

Most cars engines are cooled by water. The water flows around the *engine* and then passes through the *radiator*. It then passes through the water pump and around the engine again.

Here are the stages:

- 1 Water flows around the engine. The engine is cooled and the water is heated.
- 2 The hot water enters the radiator through the *top hose*.
- 3 It flows down through the radiator. Here it is cooled by air.
- 4 The cool water leaves the radiator through the *bottom hose*.
- 5 The water is pumped around the engine again.

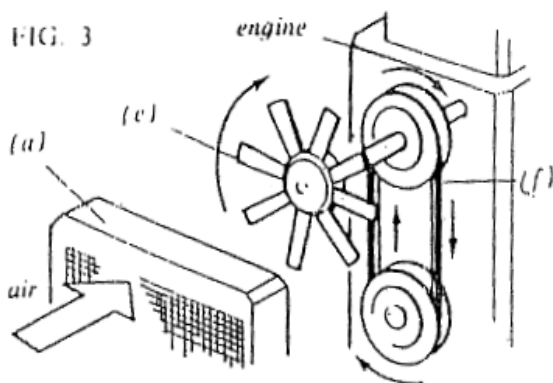
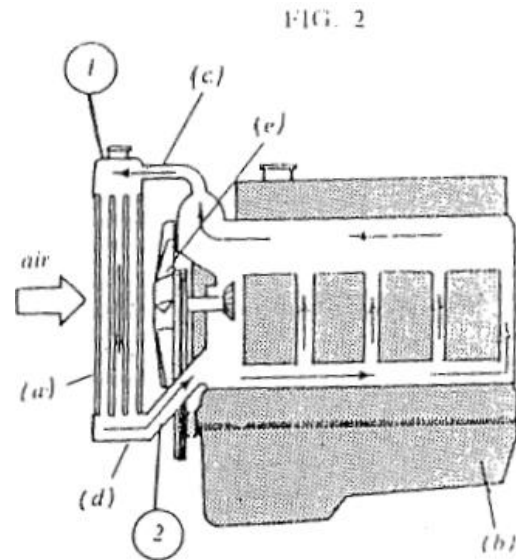

Look at FIG.3. Air is pulled through the radiator by a *fan*. This fan is turned by a *belt*, which is driven by the engine.

a- What are the objects in the diagrams called?

Example: (a) is called a radiator.

b- Answer these questions:

- (a) Look at Fig. 2. Is the water hot or cold at point ①? At point ②?
- (b) What cools the engine?
- (c) What makes the water hot?
- (d) What makes the water cool?
- (e) What pumps the water round the engine?
- (f) What pulls air through the radiator?
- (g) What does the belt turn?
- (h) What drives the belt?

Unit 3: First, Mark a hole!

Mục tiêu

Học xong bài học này, người học có khả năng:

- Đọc được từ vựng tiếng Anh chuyên ngành trong bài học;
- Sử dụng các trạng từ "first, then, next, finally...";
- Đọc hiểu, biết cách sắp xếp câu theo đúng thứ tự;
- Viết lại câu thay thế cặp từ "First... Then..." bằng trạng từ "before";
- Tìm hiểu các động từ nguyên thể để viết cấu trúc câu ngắn gọn;
- Sử dụng cấu trúc câu "to be + past participle + by + verb-ing";
- Cấu tạo, cách sử dụng các động từ "switch, press, push, pull...".



Nội dung

1. VOCABULARY:

bit /bit/	(n)	mũi khoan	mark /mɑ :k/	(v)	đánh dấu
brickwork /'brikwə:k/	(n)	cấu trúc bằng gạch	measure /'meɜ ə/	(n)	hệ đo lường
cable /'keɪbl/	(n)	cáp	meter /'mi:tə/	(n)	đo
circuit /'sə:kit/	(n)	mạch điện	nail /neɪl/	(n)	cái đinh
current /'kʌ rənt/	(n)	dòng điện	operate /'ɔ pəreit/	(v)	hoạt động
contact /'kɔ ntækt/	(n)	thiết bị nối điện	plank /plæŋk/	(n)	tấm ván
fill /fil/	(v)	đổ đầy, chứa đầy	recess /ri'ses/	(n)	thời gian ngừng
float /flaʊt/	(n)	nổi	rise /raɪz/	(n)	tăng lên
fuel /fjuəl/	(n)	nhiên liệu	saw /sɔ :/	(n,v)	cưa
grind /graɪnd/	(v)	xay, giã	(sawed, p.p.sawn)		
hi-fi (<i>high-</i> <i>fidelity</i>) /'haɪ'faɪ/	(n)	máy ghi âm, ghi băng có độ trung thực cao	sharpen /'ʃɑ :pən/	(v)	làm cho sắc, nhọn
			stone /stəʊn/	(n)	đá
hole /'həʊl/	(n)	cái lỗ	tap /tæp/	(n)	vòi nước
install /ɪn'stɔ :l/	(v)	lắp đặt	terminal /'tɜ:minl/	(n)	thiết bị đầu cuối
join /dʒɔɪn/	(v)	nối, chấp ghép	vice /vaɪs/	(n)	ê-tô
level /'levl/	(n)	mức độ	workshop /'wɜ:kʃɔ p/	(n)	xưởng
light /laɪt/	(n)	ánh sáng			

2. "FIRST, YOU MARK THE HOLE!"

Ron is showing Alan how to drill a hole in a plank of wood.

First, you mark the hole. Then, you place the wood in a vice. Next, you switch on the drill. Finally, you drill the hole.

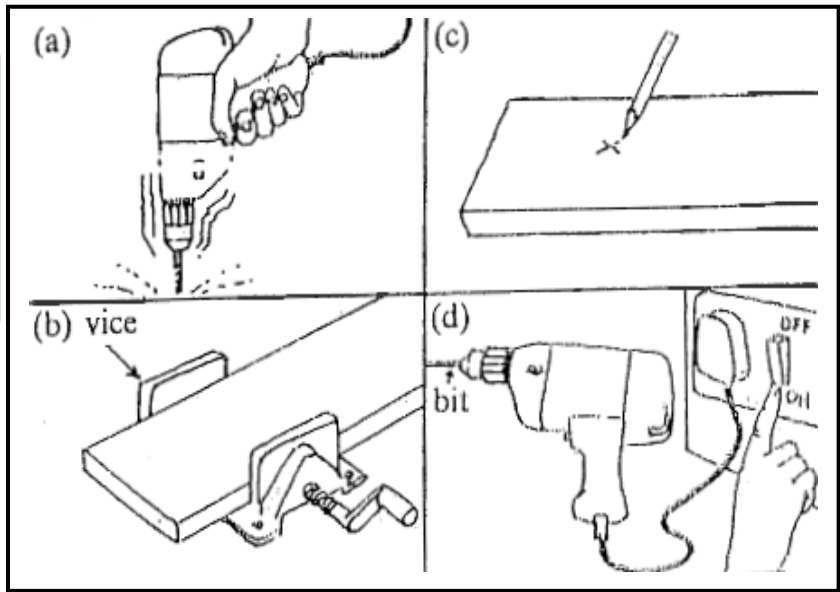

2.1 Match the pictures above with Ron's instructions:

- Example:** (1) - First, you mark the hole. - (c)
- (2) - - (...)
- (3) - - (...)
- (4) - - (...)

2.2 Put the following instructions in the correct order:

- Example:** (1) Mark the hole.

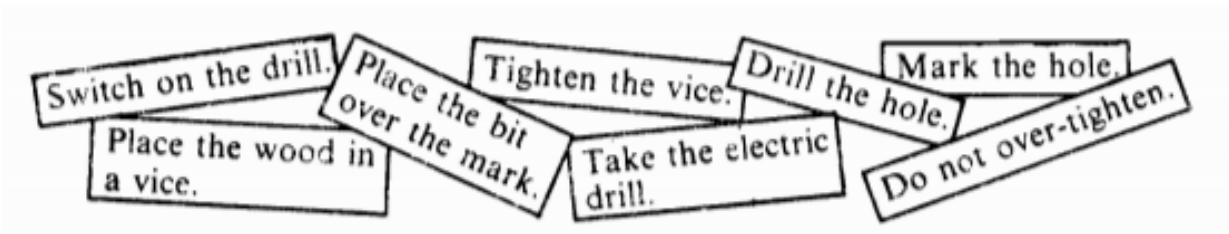

- (1)
- (2)
- (3)
- (4)
- (5)
- (6)
- (7)
- (8)

2.3 Complete Ron's words. Use the above instructions:

First, you
Then, you
Next, but don't
..... . Now, you
..... and
..... .
Finally, and



3. "SWITCH OFF BEFORE YOU TOUCH THAT WIRE"

Ron is plastering a wall in the house. Alan is giving a warning.

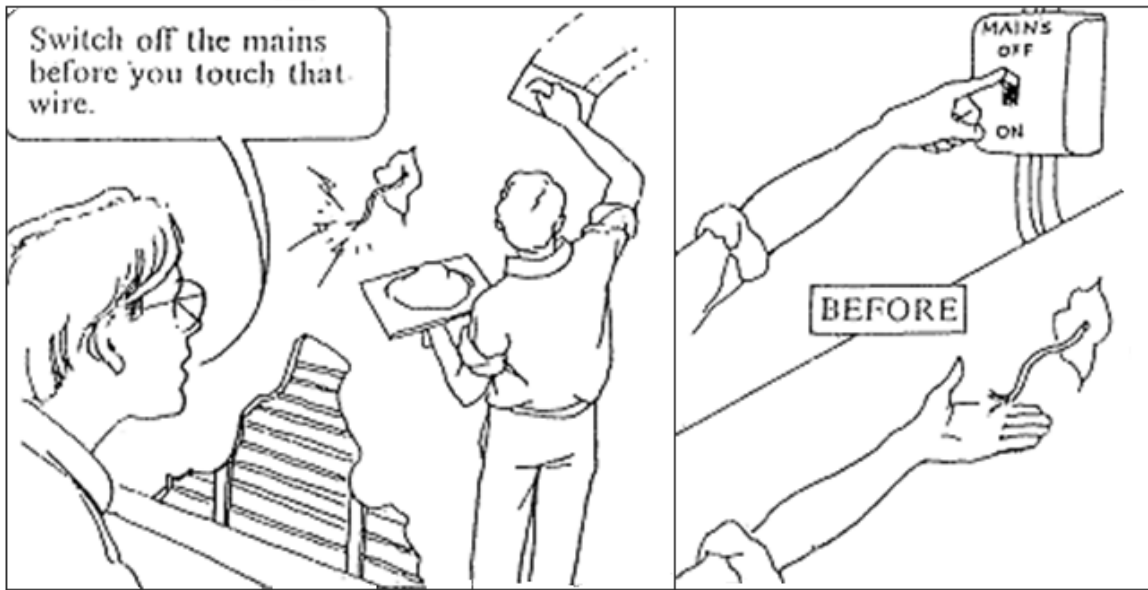

3.1 Change these pairs of instructions in the same way:

Example: (a) First switch off the mains. Then touch that wire. → **Switch off the mains before you touch that wire.**

(b) First sharpen the chisel. Then use it.
→

(c) First put petrol in the car. Then drive it.
→

(d) First mark the wood. Then saw it.
→

(e) First remove the plug from the socket. Then cut the wire.
→

(f) First put your goggles on. Then hammer the stone.
→

(g) First put the guard down. Then grind the chisel.
→

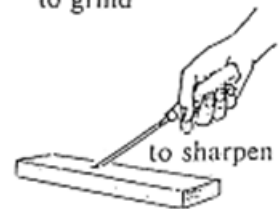
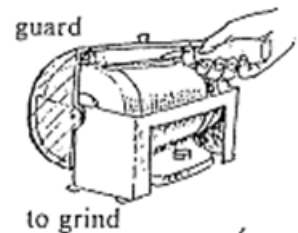

3.2 Read these sentences, then make six short instructions in the correct order:

- Put the wood in a vice before you chisel it.
- Mark the hole before you drill it.
- Switch off the machines before you leave the workshop.

Begin: (1) **Put the wood in a vice.**

- (2)
- (3)
- (4)
- (5)

End: (6) **Leave the workshop.**

4. "THE CURRENT IS STOPPED BY PRESSING THIS SWITCH"

Ron is showing Alan how to stop the current.

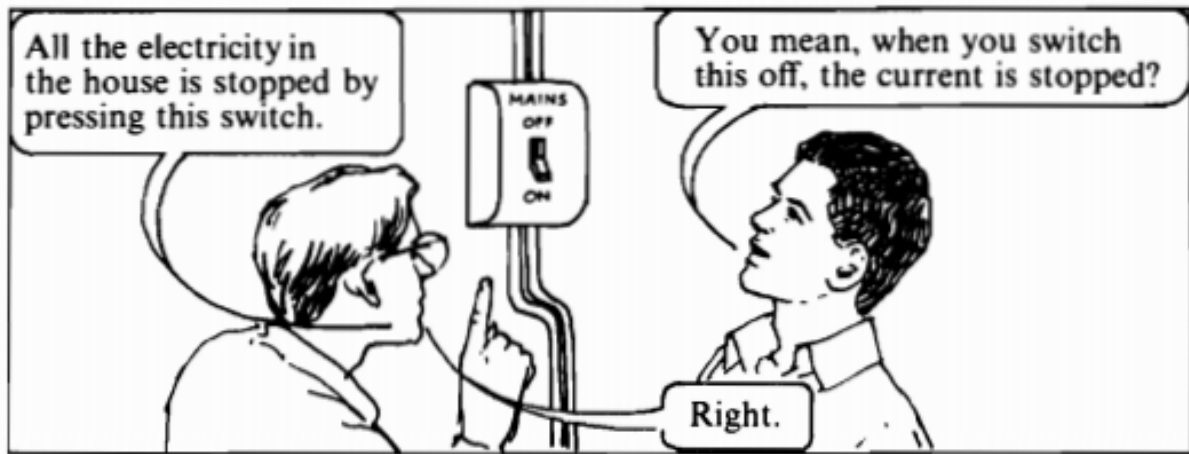

4.1 Study this:

(1) When you switch off Y, X is stopped.

= X is stopped by switching off Y

(2) You switch off Y, and X is stopped.

4.2 Learn these:

press insert push pull switch	+ ing	pressing inserting pushing pulling switching
put plug	+ t + ing + g + ing	putting plugging
examine remove	- e + ing	examining removing

4.3 Make sentences like Alan's:

Example:

(a) You press this button and the electricity is switched off.

→ **The electricity is switched off by pressing this button.**

(b) When you press that pedal, the car is stopped.

→

(c) You turn that key and the car engine is switched on.

→

(d) When you turn the handle of the tap clockwise, the water is stopped.

→

.....

(e) You hammer these nails in and the planks of wood are joined together.

→

.....

(f) When you turn this handle, the door is opened.

→

(g) Press the handle of the pump downwards and the water is pushed out.

→

.....

(h) When you pull the handle of the pump upwards, the water is stopped.

→

4.4 Look at this diagram of the circuit in Alan's house:

Example: (a) → (3) You push up the main switch.

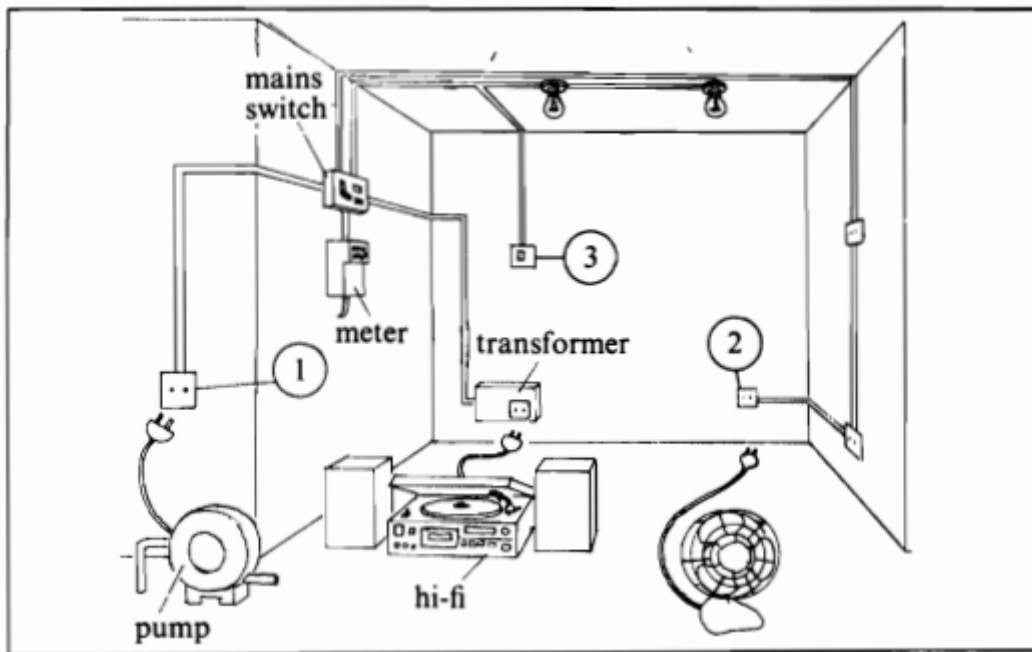

* Then answer the questions below:

- (a) You want to turn off the whole current. What do you do?
- (b) You want to switch off the ceiling lights. How do you do it?
- (c) You want to operate the hi-fi system. How do you do it?
- (d) You want to measure the flow of current. What do you do?
- (e) You want to turn on the pump. How do you do it?
- (f) You want to switch the fan on. How do you do it?

* Choose your answer from this list:

- 1 You press up switch 3
- 2 You insert the plug into socket 1.
- 3 You push up the main switch.
- 4 You put the plug into socket 2.
- 5 You plug it into the transformer.
- 6 You examine the meter.

*** Now join the above sentences together, like this:**

Example: (a) → (3): You want to turn off the whole current. You push up the main switch.

→ The whole current is turned off by pushing up the mains switch.

(b)

.....

(c)

.....

(d)

.....

(e)

.....

(f)

.....

HOW IT

Fuel warning light

Many cars have a fuel warning *light*. When the level of fuel (petrol) in the *tank* is very low, this light switches on and the driver can see that he needs more petrol. How does this light work?

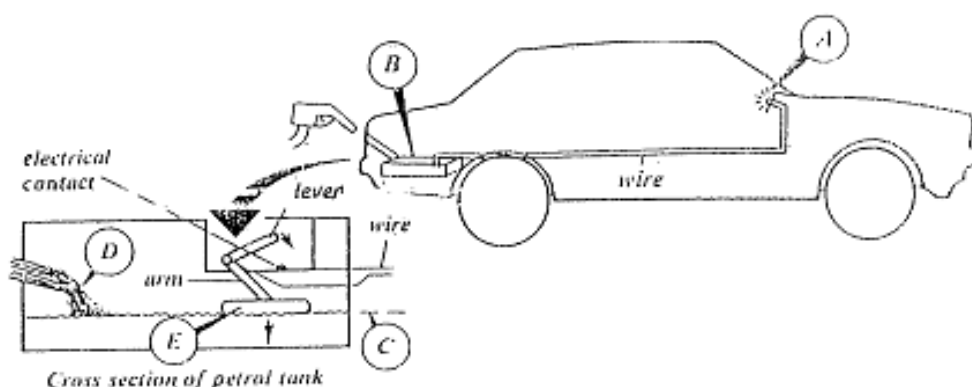

When the *level* of the fuel falls, the *float* moves downwards. When this happens, the *arm* also moves downwards and makes the *lever* touch an electrical contact. This switches on the fuel light in the car.

When the driver sees the fuel warning light, he puts more *petrol* into the tank. This makes the fuel level rise and pushes the float upwards. When the float rises, it makes the arm move upwards and this causes the lever to move upwards also. The fuel warning light then switches off.

a- What do the letters in the diagrams refer to? (Look at the words in italics in the passage.)

Example: (a) This is called a *light*.

b- Answer these questions:

(a) When does the fuel warning light go on?

(b) Why does the float go down?

(c) What makes the lever move downwards?

(d) Does the float go up or down when the fuel level rises?

(e) When does the lever move upwards?

How to install a socket

- 1 The *recess* and the *channel* (see Fig.1) are marked out with a pencil.
- 2 The *plaster* is cut away using a hammer and a *chisel*.
- 3 The *brickwork* is removed by drilling holes in it and then cutting it away with the hammer and chisel.
- 4 The *box* is inserted in the recess and screwed into place.
- 5 The *cable* is placed in the channel.

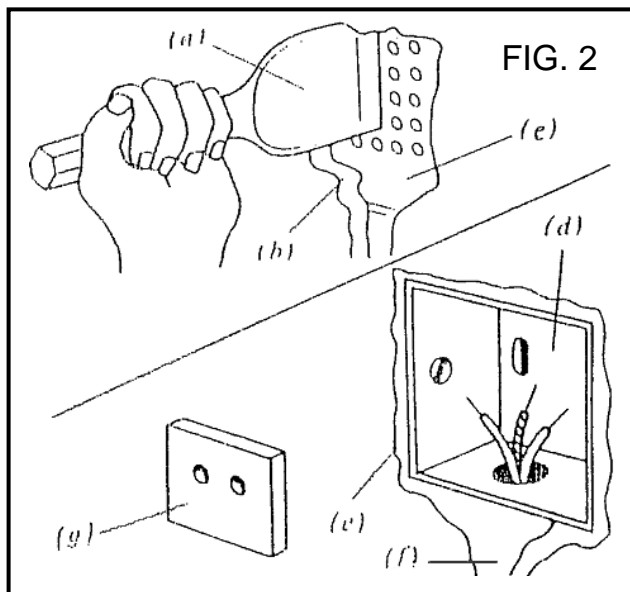
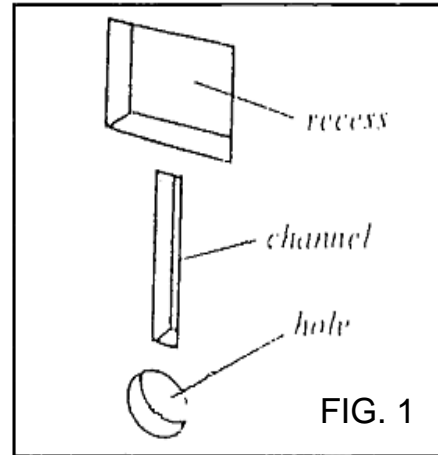

6 It is then pulled through the hole in the box.

7 The cable channel is covered. This is done by filling it with plaster, which is then painted or papered.

8 The *socket* is connected to the cable by inserting each *wire* in the *terminal* and tightening the *screw* (see Fig. 3)

9 The socket is screwed to the box.

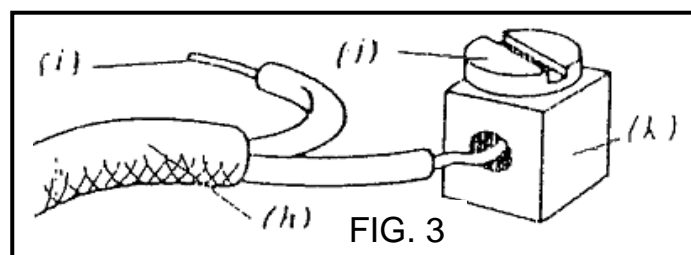

a- What are the objects in the diagrams called?

Example: (a) This is called a chisel.

(b) This is called a plaster.

b- Answer these questions:

(a) What tools do you use (i) for making out the recess?

(ii) for removing the plaster and brickwork?

(b) How do you remove the brickwork? (ANSWER: "First, you
Then, you")

(c) What do you do after you place the box in the recess?

(d) You place the cable in the channel. Then what do you put in the channel?

(e) What do you put on the plaster?

(f) How do you fix the cable to the socket? (ANSWER: " First, you
. Then, you")

Unit 4 : Safety rules

Mục tiêu

Học xong bài học này, người học có khả năng:

- Đọc được từ vựng tiếng Anh chuyên ngành trong hướng dẫn các nguyên tắc an toàn;
- Động từ khuyết thiếu "might, could, may, must, should";
- Đọc hiểu các cảnh báo an toàn;
- Đọc, viết đúng các cảnh báo an toàn;
- Phân biệt cách sử dụng hai động từ khuyết thiếu “must” và “should”;
- Viết các chỉ dẫn an toàn dưới dạng câu bị động;
- Sử dụng các động tính từ đuôi “-ed”;
- Sử dụng đại từ quan hệ “that” và “which”;
- Viết các phép tính: "add, subtract, multiply, divide";
- Đọc hiểu tài liệu về các nội quy, quy định an toàn.



Nội dung

1. VOCABULARY:

apron /'eɪprən/	(n)	cái tạp dề	lift /lift/	(v)	nhấc lên
bare /beə/	(adj)	trần	live /laɪv/	(adj)	có dòng điện
- bare wire	(n)	dây trần	overheat /'ouvə'hi:t/	(adj)	quá nóng
blinded /'blaɪndɪd/	(adj)	bị mù	overall /'ouvəro :l/	(n)	áo bảo hộ
block /blɒk/	(n)	gây trở ngại	pile /paɪl/	(n)	(một) đồng
brush /brʌʃ/	(n)	bàn chải	plate /pleɪt/	(v)	mạ
burn (pt, pp: burnt) /bɜ:n/	(v)	đốt cháy	protective /'prɒ'tektɪv/	(adj)	bảo vệ (hộ)
- get burnt	(v)	bị đốt cháy	rubber /'rʌ bə/	(n)	cao su
crack /kræk/	(n)	vết nứt	spanner /spænə/	(n)	cờ-lê
coil /kɔɪl/	(v)	cuốn	safety /'seɪfti/	(n)	an toàn
concrete /'kɒŋkri:t/	(n)	bê-tông	shock /ʃɒk/	(n)	cú choáng, giật
cuff /kʌf/	(n)	cổ tay áo	sleeve /sli:v/	(n)	ống tay áo
drum /drʌm/	(n)	cái trống	slip /slɪp/	(v)	trượt, ngã
explode /ɪks'pləʊd/	(v)	nổ tung	straighten /'streɪtn/	(v)	làm cho thẳng
finger /'fɪŋgə/	(n)	ngón tay	strike /straɪk/	(v)	đánh, gõ
fix /fɪks/	(v)	cố định	support /sə'pɔ :t/	(v)	nâng, đỡ
helmet /'helmit/	(n)	mũ bảo hiểm	twist /twɪst/	(v)	vặn
jack /dʒæk/	(n)	cái kích	weld /weld/	(v)	hàn
jam /dʒæm/	(n)	ép, kẹp, chặt	workpiece /'wɜ:kpi:s/	(n)	vật chưa gia công thành phẩm

2. "YOU MIGHT GET A SHOCK."

Alan is warning Ron.

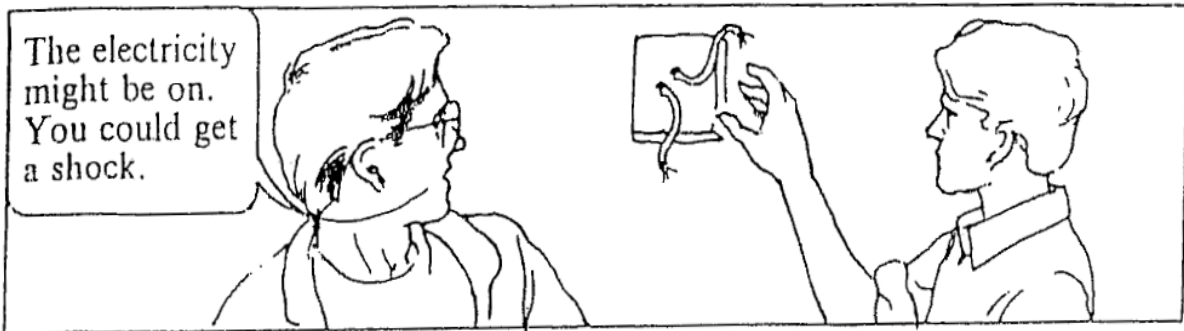

2.1 Study this:

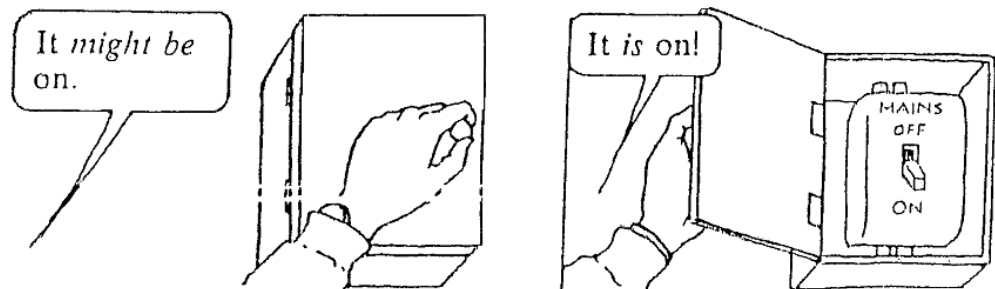

- It *might* be on.
- It *could* be on.
- It *may* be on.

2.2 Make warnings:

Example: (a) Be careful! You might slip.

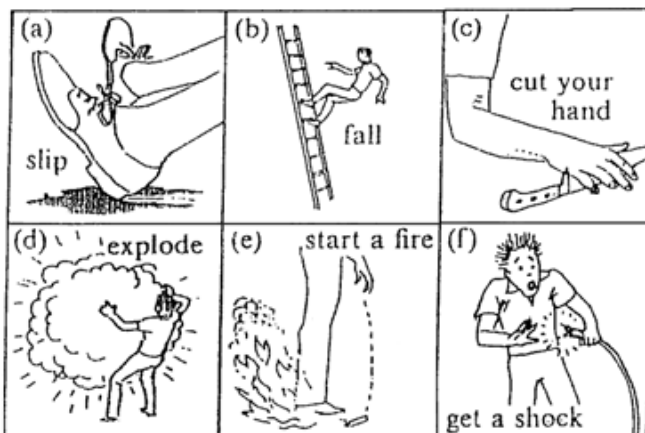

- (a) you might
- (b) you could
- (c) you may
- (d) the petrol may
- (e) you might
- (f) you could

2.3 Match the warnings with the numbers in the picture:

Example: (a) - number ④

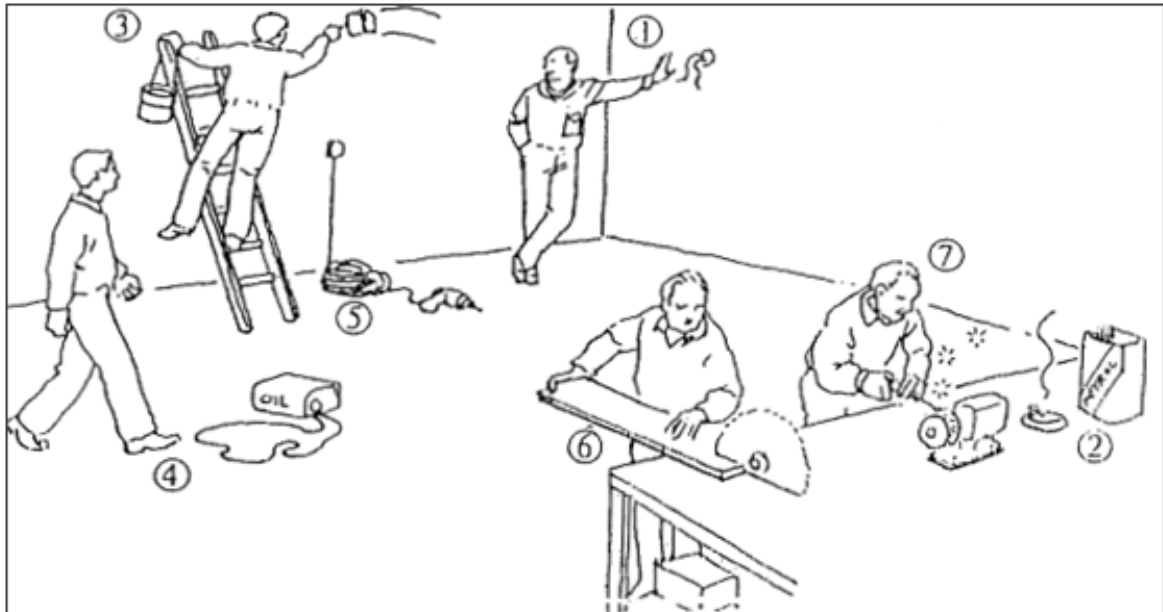

- (a) Look out! There's some oil on the floor. You may slip and get hurt.
- (b) Stop that man! He might cut his hand.
- (c) Straighten that wire! It might overheat and start a fire.
- (d) Don't touch that! You may get an electric shock and die.
- (e) Be careful! You might fall off that ladder and break a leg.
- (f) Put that cigarette out. And take the can away. It could explode.
- (g) Put the guard down and put on a pair of goggles. The chisel could break and you could get blinded.

2.4 Read these warnings and give reasons:

Example: (a) because the petrol might explode.

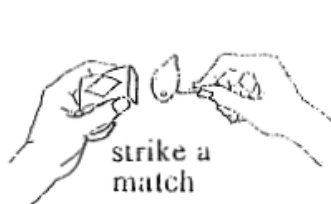

(a)



(b)



(c)

(a) Don't smoke near a petrol tank.
.....

(b) Don't take the back off a TV when the TV is on,
.....

(c) Don't use a metal ladder near electrical wire,
.....

(d) Don't strike a match in a dark room,
.....

(e) Don't support a car on pile of bricks,
.....

(f) Don't climb a ladder too close to the wall,
.....

(g) When you use a drilling machine, don't hold the workpiece with your hand,
.....

3. "YOU MUST NEVER SMOKE NEAR PETROL"

Kamal and Ron are at work. Kamal is explaining a safety rule to an apprentice. Ron is giving some advice.



3.1 Study this [1]:

RULES

(Very important)

- 1 YOU MUST NOT smoke here.
- 2 YOU MUST NEVER smoke here.
- 3 YOU MUST switch off.
- 4 YOU MUST ALWAYS switch off first.

ADVICE

(This is not as important as a RULE)

- 1 YOU SHOULD NOT use a dirty saw.
- 2 YOU SHOULD NEVER use a dirty saw.
- 3 YOU SHOULD clean all tools.
- 4 YOU SHOULD ALWAYS clean your tools.

3.2 Use SHOULD or MUST:

Example: (a) **You should** clean your tools before you use them.

- (a) Here is some advice: clean your tools before you use them.
- (b) This is a rule: switch off the electricity before you touch a bare wire.
- (c) Here is a rule: do not smoke near petrol.
- (d) This is some advice: always sharpen chisels before you use them.
- (e) Here is a rule: always wear goggles when you grind a chisel.
- (f) This is some advice: never use a screwdriver for opening a tin of paint.
- (g) Here is some advice: use a narrow brush for painting corners.
- (h) This is a rule: never do any welding without a helmet or goggles.

3.3 Study this [2]:

X YOU MUST NOT
DO THIS!



! LOOK OUT!
BE CAREFUL!



3.4 Match the pictures with the safety instructions. Then put the instruction in another way. Use YOU MUST + NOT/NEVER:

Example: (a) - 3: YOU MUST NEVER put out electrical fires with water.

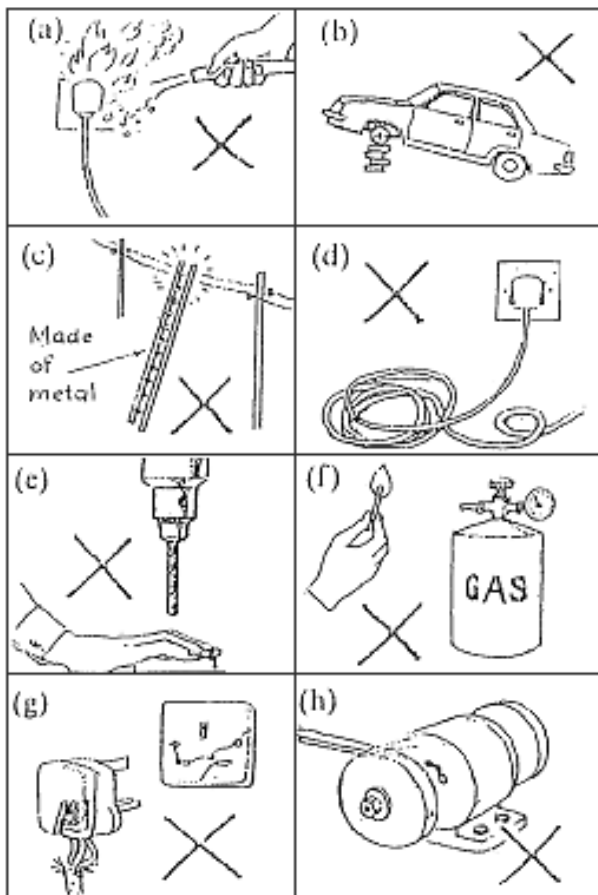

- (1) Electric wires must not be coiled.
.....
- (2) Metal plates must never be held by hand on drilling machines.
.....
- (3) Electrical fires must never be put out with water.
.....
- (4) Broken switches and sockets must never be used.
.....
- (5) Grinding machines must never be used without guards.
.....
- (6) Cars must never be supported with bricks.
.....
- (7) Metal ladders must never be placed onto electric wires.
.....
- (8) A match must never be struck near gas.
.....

3.5 Answer these questions:

(a) Why must cars never be supported on bricks?

.....
.....

(b) Why must metal ladders never be placed onto electric wires?

.....
.....

(c) Why must electric wires never be coiled?

.....
.....

(d) Why must grinding machines never be used without guards?

.....
.....

4. "TOOLS THAT ARE DAMAGED ARE DANGEROUS"

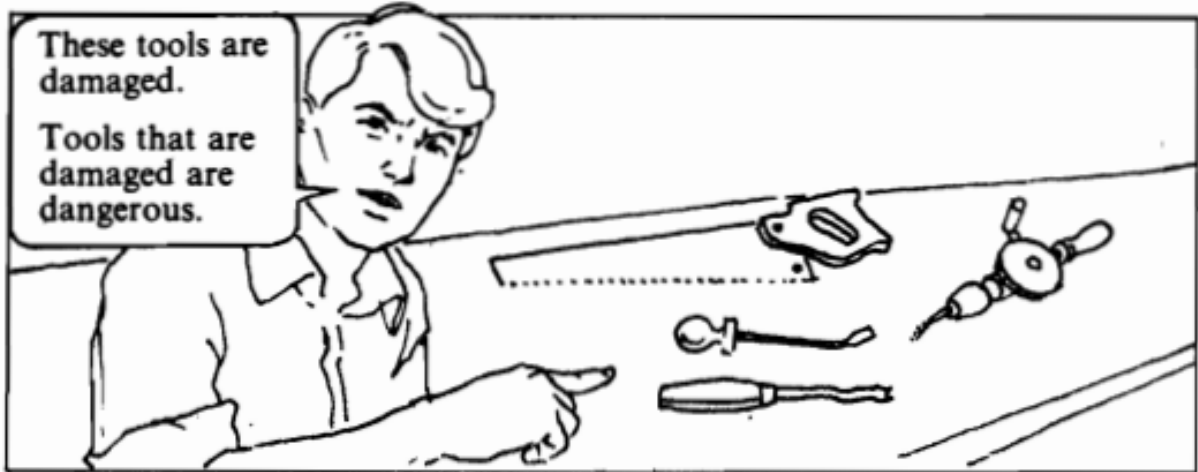

4.1 Study this [1]:

These
 mean } DAMAGED tools
 the } Tools THAT ARE DAMAGED
 same: } Tools WHICH ARE DAMAGED } are dangerous.

4.2 Match the pictures with the sentences:

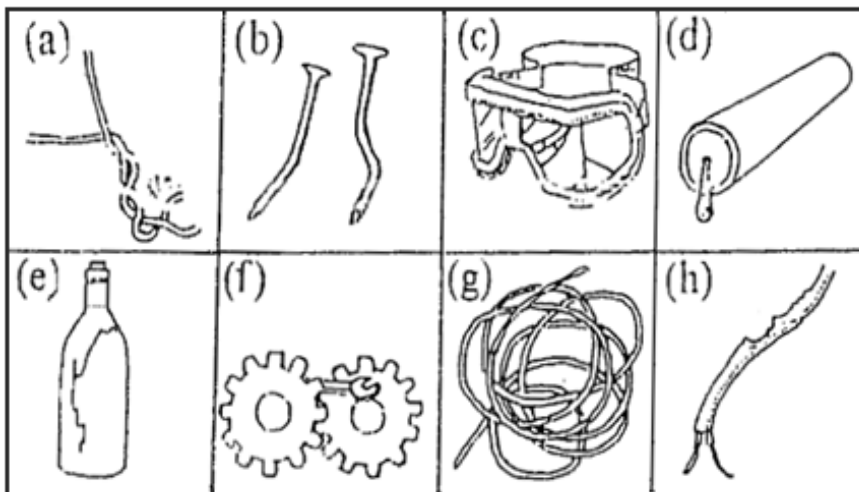

- (1) They're broken.
- (2) They're bent.
- (3) It's burnt.
- (4) They're twisted.
- (5) It's coiled.
- (6) It's cracked.
- (7) It's blocked.
- (8) They're jammed.

4.3 Make sentences:

Example:

(a) Don't use wires which are broken.

→ **These wires are broken. Don't use them.**

(b) Nails that are bent should not be used.

→ **These nails are bent. Don't use them.**

(c) Burnt wires must be thrown away.

.....

(d) Do not use wires which are coiled.

.....

(e) Pipes that are blocked should not be joined to the tank.

.....

(f) Jammed motors should be repaired.

.....

(g) Don't use goggles which are cracked.

.....

(h) Seat belts that are twisted must be straightened.

.....

4.4 Study this [2]:

Do not use ladders	{	WHICH ARE MADE OF METAL.
	}	THAT ARE MADE OF METAL.
Do not use wires	{	WHICH ARE NOT INSULATED.
	}	THAT ARE NOT INSULATED.

4.5 Match the pictures with the sentences:

Example: (a) - (7)

- (1) This wire is not insulated.
- (2) This ladder is made of metal.
- (3) This car is supported only by a jack.
- (4) This pipe is connected to an electric cable.
- (5) This switch is not fixed to the wall.
- (6) This wire is plugged in.
- (7) This TV is switched on.

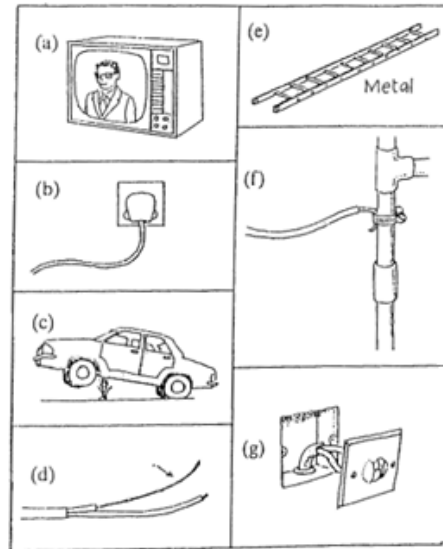

4.6 Complete these, using words from Part 4.5. (Use THAT/WHICH):

Example: (a) Do not go under a car **which is supported only by a jack.**

- (b) You must not touch a pipe
-
- (c) Do not take the back off a TV
-
- (d) When you are working near electrical wires, do not use a ladder
-
- (e) Never cut a wire
- (f) You must never touch a live wire
-
- (g) You should not use a switch
-

5. "ADD, SUBTRACT, MULTIPLY, DIVIDE"

Alan is helping Ron with his calculator.

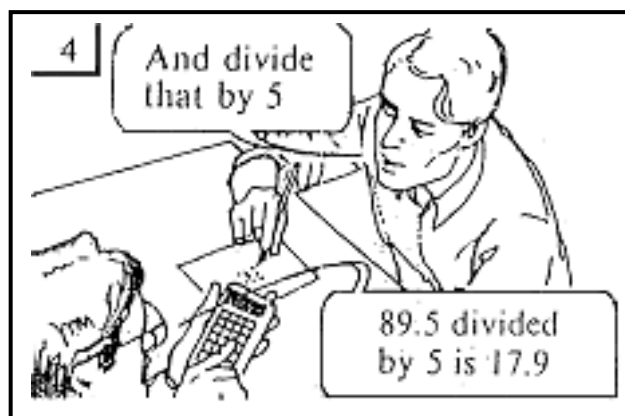
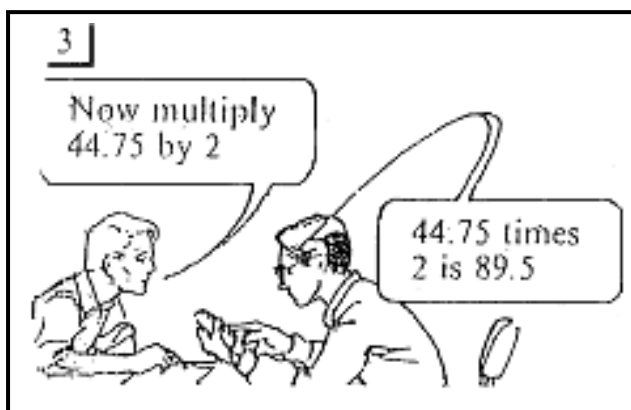
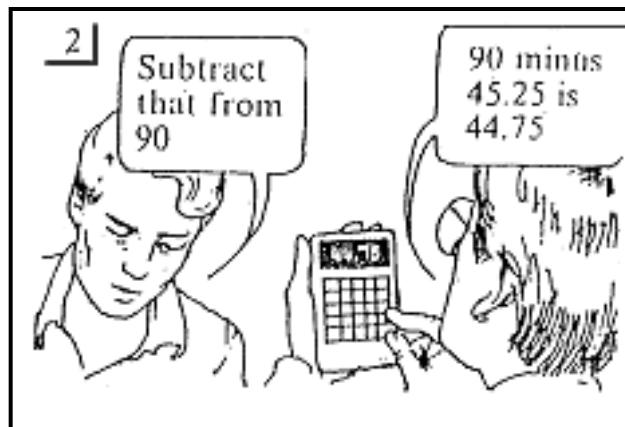
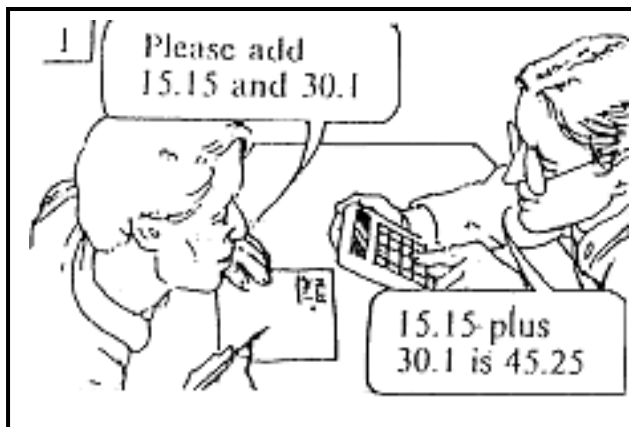

* Repeat:

A: Please add 15.15 and 30.1.

B: 15.15 plus 30.1 is 45.25.

A: Subtract that from 90.

B: 90 minus 45.25 is 44.75.

A: Now multiply 44.75 by 2.

B: 44.75 times 2 is 89.5.

A: And divide that by 5.

B: 89.5 divided by 5 is 17.9.

5.1 Read out these sums. Give the answers:

Example: (a) 13.13 plus 60.17 is 73.3.

(a) $13.13 + 60.17 = ?$

(e) $16.55 - 14 = ?$

(i) $7017 - 4004 = ?$

(b) $40.02 - 20.02 = ?$

(f) $20.08 \times 3 = ?$

(j) $16 + 2.125 = ?$

(c) $18.18 \div 9 = ?$

(g) $15 \div 3 = ?$

(k) $5 \div 2.5 = ?$

(d) $70 \times 4 = ?$

(h) $14.14 + 3.03 = ?$

(l) $13.3 \times 3 = ?$

- (a) (e) (i)
 (b) (f) (j)
 (c) (g) (k)
 (d) (h) (l)

5.2 Read out these problems. Solve them:

Example: (a) $98.4 \times 5 = 492$; $492 \div 12 = 41$

(a) Multiply 98.4 by 5 and divide the answer by 12.

.....

(b) Add 33.5 to 26.35 and subtract 45.8 from the answer.

.....

(c) Divide 40.5 by 5 and multiply the answer by 8.

.....

(d) Add 235.08 to 51.73 and subtract the answer from 326.2.

.....

(e) Subtract 54.93 from 85.01. Add 2.27. Subtract the answer from 61.9.

.....

5.3 How do we calculate these? Make instructions:

- Example:** (a) 1 Multiply 0.5 by 1.5 ($0.5 \times 1.5 = 7.5$)
 2 Now multiply 0.75 by 1 ($0.75 \times 1 = 0.75$)
 3 The volume of the box is 0.75m^3

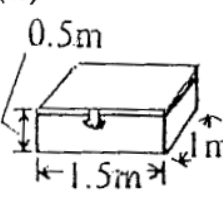
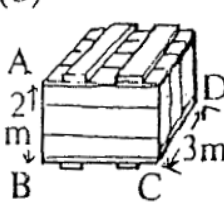
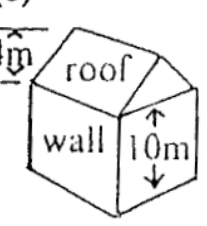
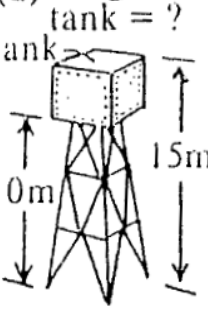
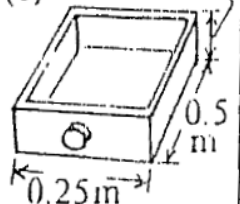
<p>(a)</p>  <p>volume = ?</p>	<p>(b)</p>  <p>volume = 21m^3 BC = ?</p>	<p>(c)</p>  <p>Height of house = ?</p>	<p>(d) Height of tank = ?</p>  <p>Tower</p>	<p>(e)</p>  <p>volume of drawer = ?</p>
--	---	---	---	--

Welding Safety Rules



CAUTION: Welding can be dangerous. Any of these accidents might happen to you: (a) you could be blinded by sparks; (b) you could get an electric shock; (c) your face, body, arms, legs or feet could be burnt; (d) there could be a fire in the workshop.

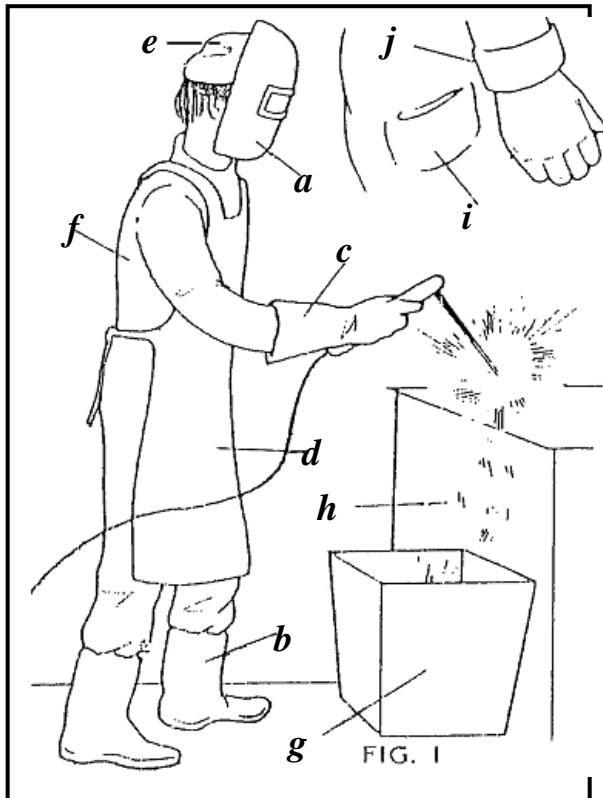

PROTECTIVE CLOTHING

(1) A mask or helmet must be worn in electric arc welding. (In gas welding, goggles can be used.)

(2) Clothes must be kept dry and clean.

(3) Thick, heavy boots must be worn.

These must be made of some insulating material such as rubber.

(4) Gloves, and apron and a cap must be worn.

(5) Overalls must have long sleeves and no pockets or cuffs.

WORKSHOP

(6) The floor must be made of concrete.

(7) There must be a metal container on the floor for the sparks.

a- What are the objects in Fig. 1 called?

b- Answer these questions:

(a) Why must you wear a mask or helmet?

(ANSWER: “Because you could / may / might...”)

(b) Why must you keep clothes dry?

(c) Why do you have to wear rubber boots?

(d) Why must you wear an apron and cap?

(e) Why must the floor be made of concrete?

(f) Why do you need a metal container on the floor?

Use of ladders – Safety Rules

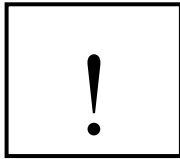

CAUTION: A ladder can be a very dangerous tool. Any of these accidents could happen to YOU: (a) the ladder could slip on an oily floor and you could fall off; (b) the top could fall backwards; (c) a door could open and push the ladder backwards or to the side; (d) a metal ladder could touch an electric wire and give you an electric shock; (e) a ladder could fall off boxes or drums.

FOLLOW THESE RULES:

Metal ladders, or wooden ones with metal wires must never be used for electrical work.

Wet or oily floors must be cleaned before a ladder is lifted.

When the ladder is near a door:

3.1 the door must be locked closed.

or 3.2 the door must be blocked open.

or 3.3 there must be a man at the bottom.

The foot of the ladder must be fixed.

The ladder must NEVER be placed on drums, boxes, etc.

The top must be fixed. It should be tied to poles, etc, using hooks, chains, ropes or a trap.

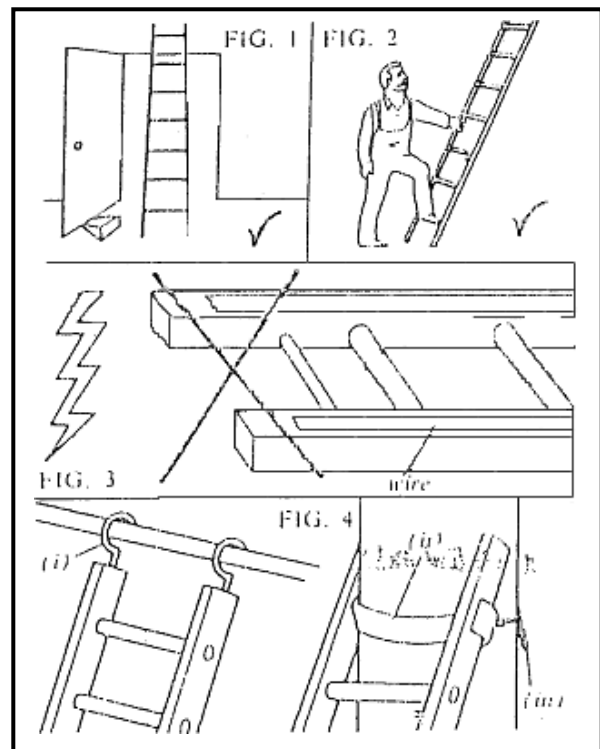

* Answer these questions:

- Which rules do Fig. 1, 2 and 3 refer to?
- Why must oily floors be cleaned? (ANSWER: “Because you might...”)
- Why do doors have to be locked closed?
- Why must the top be fixed to poles with ropes?
- Why must metal ladders not be used?
- Why must ladders not be placed on boxes?
- In Fig. 4, what are (i), (ii), and (iii)?

ENGLISH FOR ELECTRICAL AND MECHANICAL ENGINEERING



Unit 5: Circuit Elements

Mục tiêu

Học xong bài học này, người học có khả năng:

- Đọc được từ vựng tiếng Anh chuyên ngành trong bài học;
- Sử dụng các động từ "convert, provide, supply, vary, rectify...";
- Đọc hiểu tài liệu liên quan đến chủ điểm: các phần tử mạch điện;
- Thay thế các đại từ bằng các khái niệm mang nghĩa tương đương trong từng ngữ cảnh;
- Sử dụng cấu trúc câu mô tả chức năng, mục tiêu của các phần tử mạch điện.

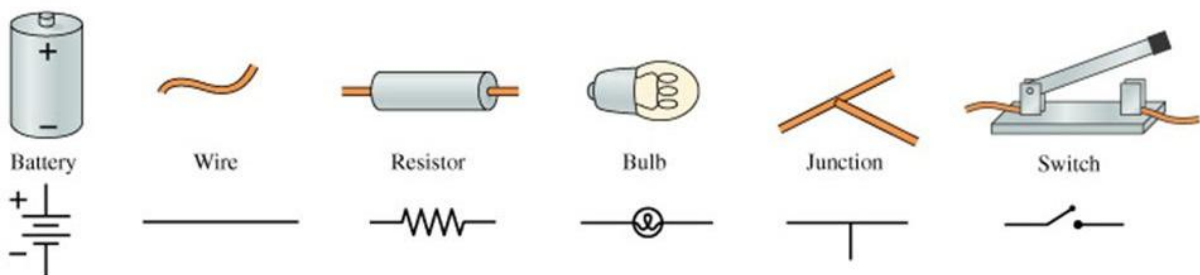

Nội dung

1. VOCABULARY:

a load /laʊd/	(n)	tải	fuse /fju:z/	(n)	cầu chì
a soldering iron /'sɒldəriŋ'aɪən/	(n)	sắt hàn	ground /graʊnd/	(n)	đất, mặt đất
a transmission system /trænz'mɪʃn'sɪstəm/	(n)	hệ thống truyền	interrupt /,ɪntə'rʌpt/	(v)	(điện học) ngắt
			limit /'lɪmɪt/	(v)	giới hạn
aboard /ə'bo:d/	(adv)	trên tàu, trên máy bay	oscilloscope /ɔ'sɪləskəʊp/	(n)	máy hiện sóng
actuate /'æktʃueɪt/	(v)	thúc đẩy	path /pɑ:θ/	(n)	đường dẫn
although /ɔ:'ðəʊ/	(conj)	dẫu cho, mặc dù	pattern /'pæt(ə)n/	(n)	mẫu, khuôn mẫu
chassis /'ʃæsi/	(n)	khung, gầm (ô tô)	potential /pə'tenʃl/	(adj)	(thuộc) điện thế
complex /'kɒmpleks/	(adj)	phức tạp	pronoun /'prəʊnaʊn/	(n)	đại từ
comprise /kəm'praɪz/	(v)	gồm có, bao gồm	protect /prə'tekt/	(v)	bảo vệ
conduct /'kɒndʌkt/	(v)	(vật lý) dẫn	provide /prə'vaɪd/	(v)	cung cấp
control /kən'trəʊl/	(v)	điều khiển	purpose /'pɜ:pəs/	(n)	mục đích, ý định
convert /kən've:t/	(v)	đổi, biến đổi	regulate /'regjuleɪt/	(v)	điều chỉnh, sửa lại cho đúng
describe /dɪ'skraɪb/	(v)	miêu tả	relay /ri'leɪ/	(n)	cái ngắt mạch, rơ le
current /'kʌrənt/	(n)	dòng điện	rheostat /'ri:əstæt/	(n)	cái biến trở, hộp số
cut-out /'kʌt,aut/	(n)	cầu chì, cầu chảy	satellite /'sætəlaɪt/	(n)	vệ tinh
device /dɪ'vaɪs/	(n)	thiết bị	section /'sekʃn/	(n)	1. đoạn, khúc, phần 2. mục (của tài liệu)
difference /'dɪfrəns/	(n)	sự khác nhau	slide /slɑɪd/	(v)	trượt
disconnect /,dɪskə'nektə/	(n)	dao cách ly	solar cell /'səʊlə'sel/	(n)	tấm pin năng lượng mặt trời
electromotive force /ɪ'lektroʊmɒtɪv fɔ:s/	(n)	sức điện động	source /so:s/	(n)	nguồn
element /'elɪmənt/	(n)	1. yếu tố 2. nguyên tố 3. (điện học) pin	space /'speɪs/	(n)	khoảng trống
emphasize /'emfəsaɪz/	(v)	nhấn mạnh	supply /sə'plaɪ/	(v)	cung cấp, tiếp tế
establish /ɪs'tæblɪʃ/	(v)	thành lập	transformer /trænz'fɔrmə/	(n)	máy biến thế, máy biến áp
flashlight /flæʃlaɪt/	(n)	đèn pin	voltage /'vəʊltɪdʒ/	(n)	điện thế, điện áp
flow /fləʊ/	(v)	chảy	wire-clippers /waɪə'klɪpə/	(n)	kìm tuốt dây
for instance /fɔ'ɪnstəns/	(conj)	ví dụ như			

2. READING COMPREHENSION:

2.1 Rewrite the following sentences, replacing the words in **bolds** with expressions from the passage which have a similar meaning.

- (a) A lamp **converts** electrical energy into light.
.....
- (b) The generator **provides** the circuit with electromotive force.
.....
- (c) The metal **frame** of the oscilloscope is part of its transmission system.
.....
- (d) The rheostat **controls** the current flow in the circuit.
.....
- (e) A battery of solar cells **supplies** power to the circuit.
.....

Current moves from a point of high potential energy to one of low potential. It can only do so if there is a path for it to follow. This path is called an electric circuit. All circuits contain four elements: a source, a load, a transmission system and a control.

5 The source provides the electromotive force. This establishes the difference in potential which makes current flow possible. The source can be any device which supplies electrical energy. For example, it may be a generator or a battery.

10 The load converts the electrical energy from the source into some other form of energy. For instance, a lamp changes electrical energy into light and heat. The load can be any electrical device.

15 The transmission system conducts the current round the circuit. Any conductor can be a part of a transmission system. Most systems consist of wires. It is often possible, however, for the metal frame of a unit to be one section of its transmission system. For example, the metal chassis of many electrical devices are used to conduct current. Similarly the body of a car is part of its electrical transmission system.

20 The control regulates the current flow in the circuit. It may control the current by limiting it, as does a rheostat, or by interrupting it, as does a switch.

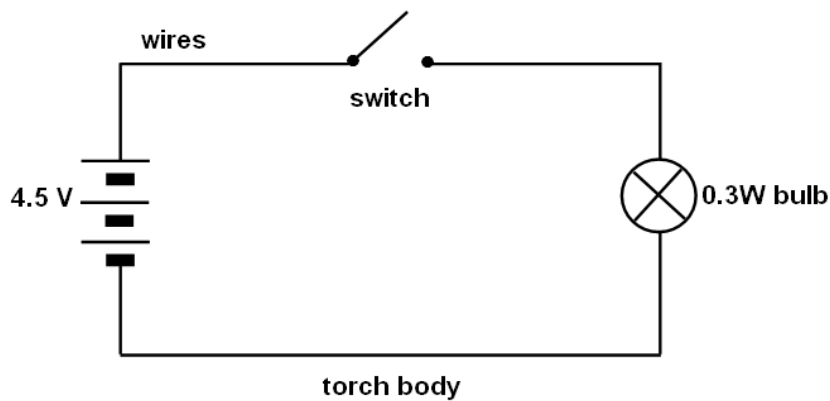

FIGURE 1

Study Figure 1. In this simple flashlight circuit, the source comprises three 1.5 V cell in series. The load is a 0.3 W bulb. Part of the transmission system is the metal body of the flashlight, and the control is a sliding switch.

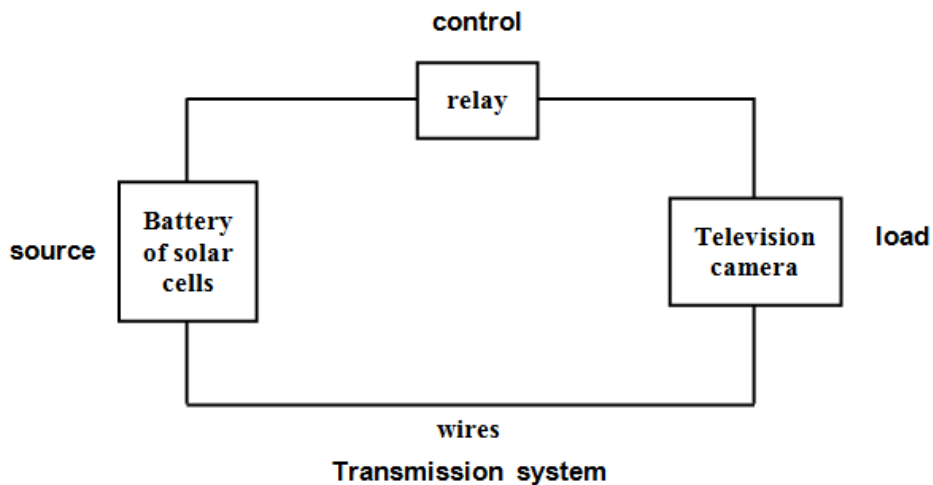

FIGURE 2

25 Compare Figure 2. The function of this circuit is to operate a television camera aboard a space satellite. Here the source is a battery of solar cells. A solar cell is an electric cell which converts sunlight into electrical energy. The load is the television camera. The transmission system is the connecting wires. The control is a relay actuated by transmissions from
 30 ground control. Although the function of this circuit is much more complex than that of the flashlight, it too consists of the four basic elements.

2.2 Contextual reference. What do the pronouns in **bolds** refer to?

(a) Current moves from a point of high potential energy to **one** of low potential.

- 1. current
- 2. energy
- 3. a point

(b) For example, **it** may be a generator or a battery.

- 1. the source
- 2. a device
- 3. electromotive force

(c) It is often possible, however, for the metal frame of a unit to be one section of **its** transmission system.

- 1. the metal frame's
- 2. the unit's
- 3. the circuit's

(d) Although the function of this circuit is much more complex than that of the flashlight, **it** too consists of the four basic elements.

- 1. this circuit
- 2. the function
- 3. flashlight

2.3 Check facts and ideas. Decide if these statements are true or false. Quote from the passage to support your decisions. Correct the false sentences.

(a) A difference in potentials required before current can flow in a circuit.

.....

(b) A generator is a source of electromotive force.

.....

(c) Loads convert electric energy into light and heat.

.....

(d) Transmission systems must consist of wires.

.....

(e) A rheostat may be used as a control.

.....

(f) The load in the flashlight circuit is a bulb.

.....

(g) The source in the satellite circuit is a solar cell.

.....

(h) The current flow in the satellite circuit is generated by a relay.

.....

(i) The flashlight circuit differs basically from the satellite circuit.

.....

3. LANGUAGE STUDY:

Describing function

When we answer the question What does X do?, we describe the function of X.

** What does the fuse do? - It protects a circuit.*

We can emphasize function by using this pattern:

- The function of a fuse is to protect a circuit.

** Here are some circuit symbols. Label them and describe their function. For example:*

⑤ - h → *It's called a transformer. It steps AC voltages up or down.*

This list of functions may help you.

- | | |
|-------------------------------------|-------------------------------------|
| (a) varies capacitance in a circuit | (f) protects a circuit |
| (b) rectifies alternating current | (g) varies the current in a circuit |
| (c) adds resistance to a circuit | (h) steps AC voltages up or down |
| (d) measures very small currents | (i) receives RF signals |
| (e) breaks a circuit | (j) measures voltages |

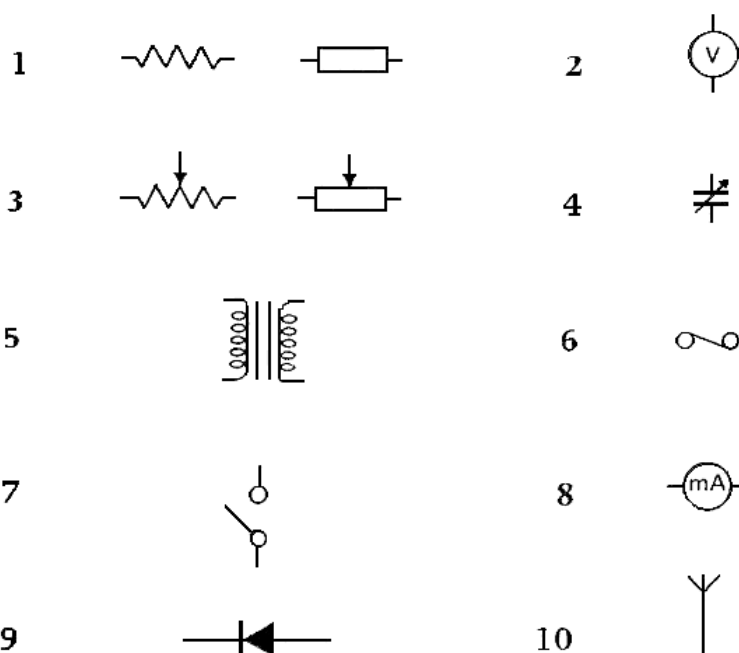

4. WRITING: Describing purpose

When we answer the question What is X for?, we describe the purpose of X.

** What is an ammeter for? - It is for measuring current.*

Other ways we can describe the purposes of an ammeter are:

1. It is used for measuring current.
2. It is used to measure current.
3. We measure current with an ammeter.
4. We measure current using an ammeter.

**** Now describe the purposes of these instruments and tools using any of the structures presented above.***

1. A voltmeter

.....
.....
.....



2. A milliammeter

.....
.....
.....



3. A megohmmeter

.....
.....
.....



4. An ohmmeter

.....
.....
.....



5. A current transformer

.....
.....
.....



6. A voltage transformer

.....
.....
.....



7. An alternating current disconnecter

.....
.....
.....



8. An HV cut-out

.....
.....
.....



9. A transformer substation - kiosk

.....
.....
.....



10. An one pillar transformer substation

.....
.....
.....



Unit 6: The Electric motor

Mục tiêu

Học xong bài học này, người học có khả năng:

- Đọc được từ vựng tiếng Anh chuyên ngành về động cơ điện;
- Luyện tập hai kỹ năng đọc hiểu trong tiếng Anh: đọc lướt (skimming) và đọc tỉ mỉ (scanning);
- Quan sát hình vẽ, sơ đồ kỹ thuật và viết nội dung mô tả ứng với hình vẽ, sơ đồ đó;
- Sử dụng các cấu trúc câu mô tả chức năng, hoạt động của động cơ điện.
- Sử dụng các động từ "screw, solder, attach, wire...".

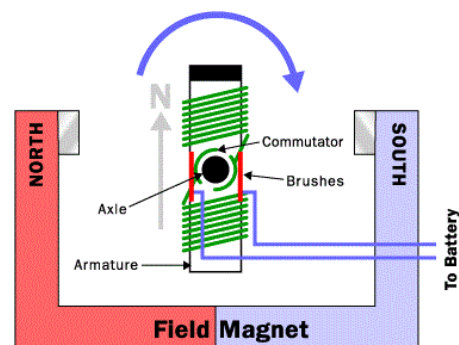
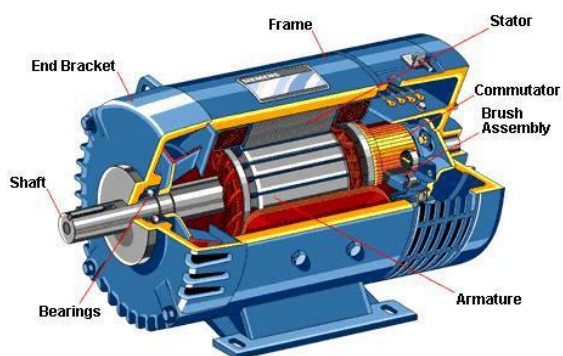

Nội dung

1. VOCABULARY:

alternating current (AC) /'ɔ :ltə:neitiŋ'kʌ rənt/	(n)	dòng điện xoay chiều	latch /lætʃ/	(n)	chốt cửa, then
a force /fɔ :s/	(n)	năng lượng	loop /lu:p/	(n)	cửa (điện học) cuộn, lõi
a means /mi:nz/	(n)	phương tiện	necessary /'nesisəri/	(n)	cần thiết
accurate /'ækjurit/	(v)	chính xác	overcome /,ouvə'kʌ m/	(v)	tìm cách vượt qua
alternate /ɔ :l'tə:nət/	(v)	xen kẽ, luân phiên	pole /poul/	(n)	cực
apart /ə'pɑ :t/	(adv)	về một bên, xa	pressure /'preʃə(r)/	(n)	sức ép, áp suất, áp lực
armature /'ɑ :mætʃə/	(n)	ra	principle /'prinsəpl/	(n)	nguyên lý
bearing /'beəriŋ/	(n)	lỗi, phản ứng	protect /prə'tekt/	(v)	bảo vệ
bolt /bould/	(n)	cái đệm, vòng bi	punctuation /,pʌ ŋktʃu'eifn/	(n)	phép chấm câu
breaker /'breikə/	(n)	bu lông (KT)	remains /ri'meinz/	(n)	cái còn lại
brush bar /brʌ ʃ bɑ :/	(n)	cái ngắt điện, cái công tắc	release /ri'li:s/	(v)	thả, thả, phóng
commutator /'kɔ mju:teitə/	(n)	chổi than	repetitive /ri'petətiv/	(adj)	thích lặp đi, lặp lại
core /kɔ :/	(n)	cái đảo mạch, vành đồng	reset /,ri:'set/	(v)	vặn lại, lắp lại
design /di'zain/	(v)	lỗi, ruột (KT)	reverse /ri'və:s/	(v)	đảo, nghịch, ngược lại
direct current (DC) /di'rekt 'kʌ rənt/	(n)	thiết kế, phác họa	segment /'segmənt/	(n)	phần
driving /'draiviŋ/	(n)	dòng điện một chiều	sentence building /'sentəns 'bildiŋ/	(n)	dựng câu, đặt câu
end /end/	(n)	truyền, truyền động	set up /'setʌ p/	(v)	sắp đặt
excessive /ik'sesiv/	(adj)	giới hạn, đoạn cuối	shaft /ʃɑ :ft/	(n)	trục
fault /fɔ :lt/	(n)	quá mức, thừa	solenoid /'souləno id/	(n)	cuộn dây kim loại có từ tính khi có dòng điện chạy qua (sôlênoit)
fed to /fed tu/	(v)	sự dò rỉ, sự lạc	spin /spin/	(v)	làm quay tròn
form /fɔ :m/	(v)	dẫn đến	spring /sprɪŋ/	(n)	lò xo, nhíp xe
holder /'houldə/	(n)	làm thành, tạo thành	tension /'tenʃn/	(n)	điện thế, sức điện động
hub /hʌ b/	(n)	mâm cặp, vòng kẹp	terminal /'tə:min/	(n)	cực, đầu nối
	(n)	trục bánh xe	towards	(adv)	về phía

interaction (n) sự tương tác /tə'wɔ :dz/ typical /'tipikl/ (adj) đặc thù, đặc trung
 /,intər'ækʃn/

2. READING COMPREHENSION:

2.1 Working in your group, list as many items as you can in the home which use electric motors. Which rooms has the most items?

*** Reading - Skimming**

You may study scanning - locating specific information quickly. Another useful strategy is reading a text quickly to get a general idea of the kind of information it contains. You can then decide which parts of the text are worth reading in more detail later, depending on your reading purpose. This strategy is called *skimming*.

2.2 Skim this text and identify the paragraphs which contain information on each of these topics. The first one has been done for you.

- (a) What electric motors are used for ***paragraph 1***.....
- (b) The commutator
- (c) Why the armature turns
- (d) Electromagnets
- (e) Effect of putting magnets together
- (f) The armature

5 In an electric motor an electric current and magnetic field produce a turning movement. This can drive all sorts of machines, from wrist-watches to trains. The motor shown in Fig.1 is for a washing machine. It is a universal motor, which can run on direct current or alternating current. *para 1*

10 An electric current running through a wire produces a magnetic field around the wire. If an electric current flows around a loop of wire with a bar of iron through it, the iron becomes magnetized. It is called an electromagnet; one end becomes a north pole and the other a south pole, *para 2*

depending on which way the current is flowing around the loop.

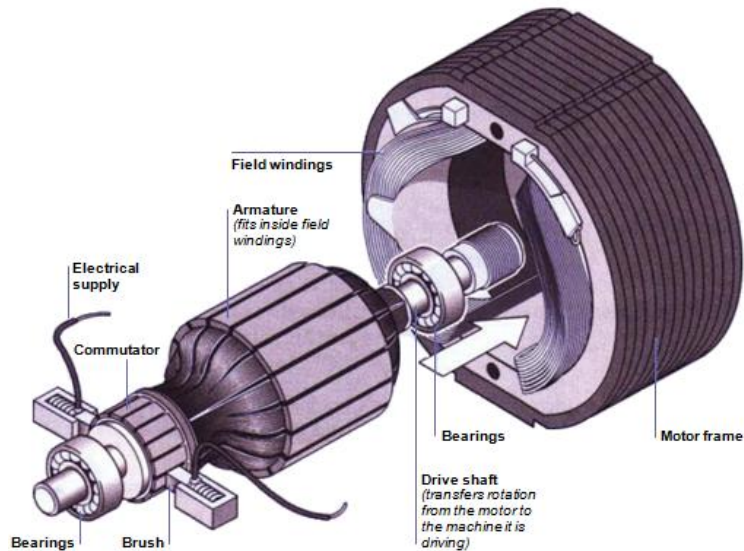

15 If you put two magnets close together, like poles - for example, two north poles - repel each other, and unlike poles attract each other. *para 3*

20 In a simple electric motor, like the one shown in Fig.2, a piece of iron with loops of wire round it, called an armature, is placed between the north and south poles of a stationary magnet, known as the field magnet. When electricity flows around the armature wire, the iron becomes an electromagnet. *para 4*

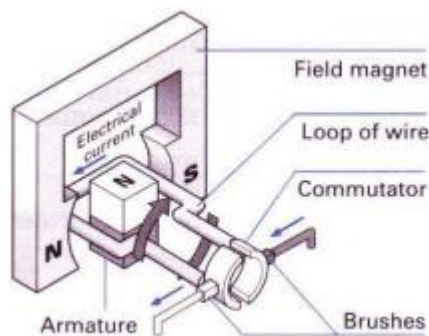

25 The attraction and repulsion between the poles of this armature magnet and the poles of the field magnet make the armature turn. As a result, its north pole is close to the south pole of the field magnet. Then the current is reversed so the north pole of the armature magnet becomes the *para 5*

south pole. Once again, the attraction and repulsion between it and the field magnet make it turn. The armature continues turning as long as the direction of the current, and therefore its magnetic poles, keeps being reversed.

para 6

- 30 To reverse the direction of the current, the ends of the armature wire are connected to different halves of a split ring called a commutator. Current flows to and from the commutator through small carbon blocks called brushes.
- 35 As the armature turns, first one half of the commutator comes into contact with the brush delivering the current, and then the other, so the direction of the current keeps being reversed.

Source: Adapted from "*Inside out: Electric Motor*", Education Guardian

2.3 Match each of these diagrams with the correct description A, B, C or D.

One of the descriptions does *not* match any of the diagrams. (The diagrams are in the correct sequence, but the descriptions are not.)

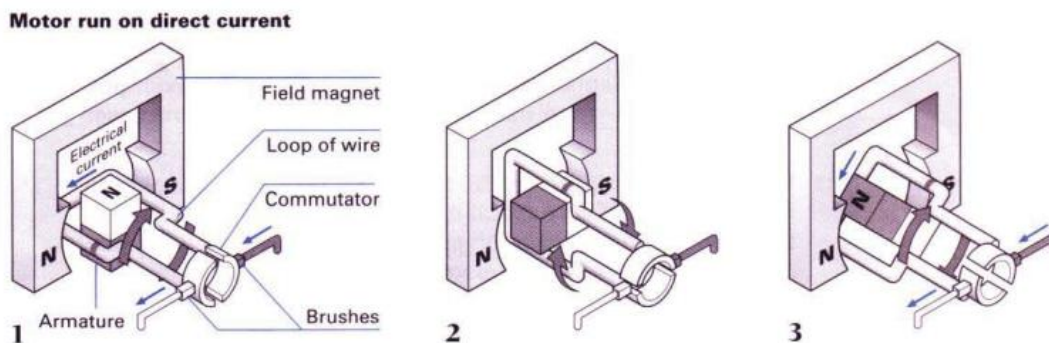

A

The armature turns a quarter of a turn. Then electric contact is broken because of the gap in the commutator, but the armature keeps turning because there is nothing to stop it.

B

When current flows, the armature becomes an electromagnet. Its north pole is attracted by the south pole and repelled by the north pole of the field magnet.

C

When a universal motor is run on direct current, the magnetic poles in the armature change while those of the field magnet remain constant.

D

When the commutator comes back into contact with the brushes, current

flows through the armature in the opposite direction. Its poles are reversed and the turn continues.

3. LANGUAGE STUDY: **Describing function**

Try to answer this question:

What does an electric motor do?

When we answer a question like this, we describe the function of something.

We can describe the function of an electric motor in this way:

- An electric motor converts electrical energy to mechanical energy.

We can emphasize the function like this:

- The function of an electric motor is to convert electrical energy to mechanical energy.

*** Match each of these motor components to its function, and then describe its function in a sentence.**

Component	Function
(a) armature	(1) transfers rotation from the motor
(b) bearings	(2) create an electromagnetic field
(c) brushes	(3) converts electromagnetic energy to rotation
(d) commutator	(4) reverses the current to the armature
(e) drive shaft	(5) support the drive shaft
(f) field windings	(6) supply current to the armature

4. WRITING: Describing components

4.1 Dismantle this simple DC motor into its components by completing the labelling of the chart below.

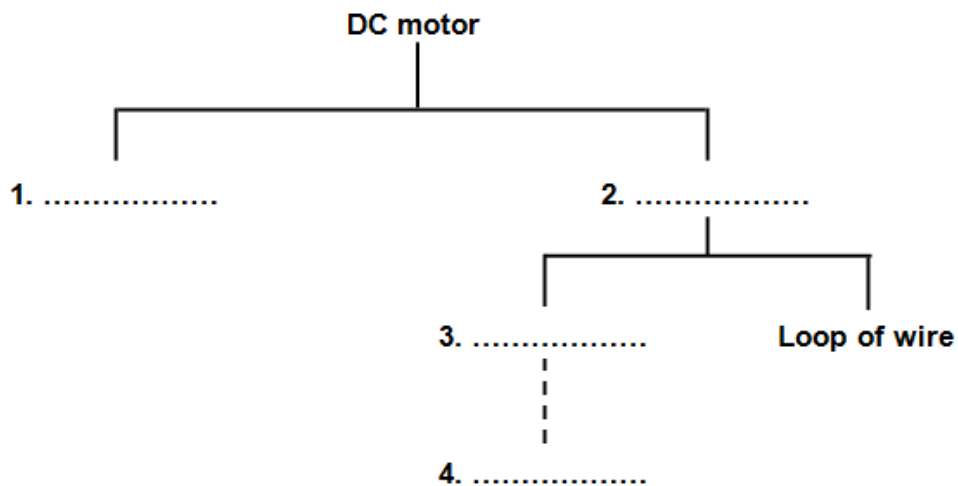
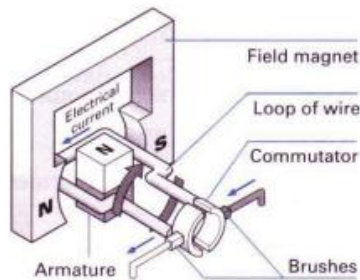

4.2 Now study this description of the motor.

A simple dc motor *consists of* a field magnet and an armature. The armature *is placed between* the poles of the magnet. The armature *is made up of* a loop of wire and a split ring *known as* a commutator. The loop *is connected to* the commutator. Current is supplied to the motor through carbon blocks *called* brushes.

To write a description, you need to use language to:

1 dismantle a piece of equipment into its main parts. These expressions will help:

consists of

X

A A *is made up of* X and Y

is composed of Y

2 name components:

Carbon blocks *known as* brushes
called

3 locate components:

The armature *is placed between* the poles.

4 connect components:

The loop *is connected to* the commutator.

* **Word study**

Study these expressions for describing how components are connected to each other.

A is bolted to B. = A is connected to B with bolts.

A is welded to B. = A is connected to B by welding.

Explain each of these methods of connection.

- (1) screwed
- (2) soldered
- (3) attached
- (4) wired
- (5) bonded
- (6) glued
- (7) riveted
- (8) welded
- (9) brazed
- (10) nailed

Unit 7: Transformers

Mục tiêu

Học xong bài học này, người học có khả năng:

- Đọc được từ vựng tiếng Anh chuyên ngành trong bài học;
- Đọc hiểu các tài liệu liên quan đến chủ điểm: Máy biến áp;
- Sử dụng các cấu trúc câu mô tả chức năng, bộ phận của các trang thiết bị, máy móc;
- Phân tích hình vẽ và viết các đoạn văn ngắn minh họa hình vẽ.

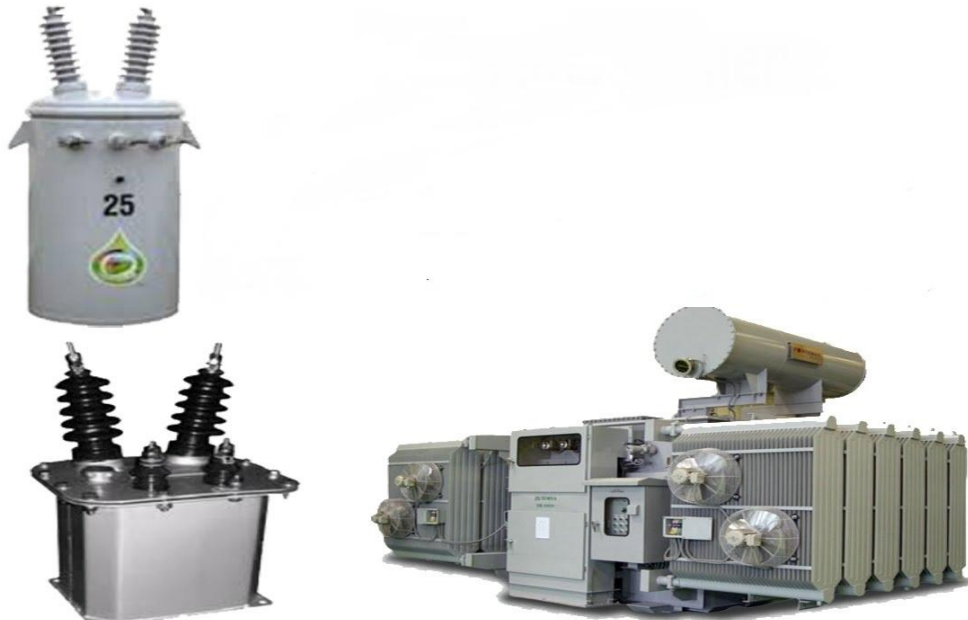

Nội dung

1. VOCABULARY:

a carbon resistor	(n)	điện trở cac bon	magnitude	(n)	cường độ, âm lượng
<i>/'kɑ :bən ri'zistə/</i>			<i>/'mægnitju:d/</i>		
amplitude	(n)	biên độ	mount	(v)	đặt, đóng vào
<i>/'æmplitju:d/</i>			<i>/maunt/</i>		
basically	(adv)	cơ bản là	obtain	(v)	đạt, giành được
<i>/'beisikəli/</i>			<i>/əb'tein/</i>		
centre	(n)	trung tâm	output	(n)	đầu ra
<i>/'sentə/</i>			<i>/'autput/</i>		
choke	(n)	cuộn cảm kháng	own	(v)	của chính mình, của riêng mình
<i>/tʃouk/</i>			<i>/oun/</i>		
component	(n)	thành phần, bộ phận	oxidize	(v)	bị gỉ, bị ô xi hóa
<i>/kəm'pounənt/</i>			<i>/'ɔ ksidaiz/</i>		
decrease	(v,n)	giảm	piece	(n)	mảnh, bộ phận
<i>/'di:kri:s/</i>			<i>/pi:s/</i>		
description	(n)	miêu tả	possible	(adj)	có thể
<i>/dis'kripʃn/</i>			<i>/'pɔ səbl/</i>		
diagram	(n)	sơ đồ	presence	(n)	sự hiện diện, sự có mặt
<i>/'daigræm/</i>			<i>/'preznz/</i>		
draw	(v)	vẽ	primary	(adj)	sơ cấp
<i>/drɔ :/</i>			<i>/'praɪməri/</i>		
eddy	(v)	làm xoáy lốc	reduce	(v)	giảm, giảm bớt, hạ
<i>/'edi/</i>			<i>/ri'dju:s/</i>		
equipment	(n)	trang bị	secondary	(adj)	thứ cấp
<i>/'kwɪpmənt/</i>			<i>/'sekəndri/</i>		
filament bulb	(n)	bóng đèn dây tóc	sheet	(n)	lá, tấm, phiến, tờ
<i>/'filəmənt bʌ lb/</i>			<i>/ʃi:t/</i>		
former	(adv)	cái trước, vấn đề trước	similar	(adj)	tương tự
<i>/'fɔ :mə/</i>			<i>/'similə/</i>		
illustrate	(v)	minh họa	so that	(adv)	để, để cho, dạng
<i>/'iləstreɪt/</i>			<i>/sɔ ðæt/</i>		
increase	(v)	tăng	turn	(v)	vòng, quay, xoay
<i>/'ɪnkri:s/</i>			<i>/tɜ:n/</i>		
input	(n)	đầu vào	variable	(adj)	có thể thay đổi
<i>/'ɪnput/</i>			<i>/'veəriəbl/</i>		
insulate	(v)	cô lập, cách ly	virtually	(adv)	thật sự, thực sự
<i>/'ɪnsjuleɪt/</i>			<i>/'vɜ:tʃuəli/</i>		
item	(n)	khoản, mục	voltage	(n)	điện thế
<i>/'aɪtəm/</i>			<i>/'vɔlʃɪdʒ /</i>		
lamination	(n)	sự cán mỏng, sự dát mỏng	winding	(n)	khúc quanh, vòng quanh
<i>/,ləmi'neiʃn/</i>			<i>/'waɪndɪŋ/</i>		
limb	(n)	bờ, rìa	wound	(v)	quấn (quanh)
<i>/lim/</i>			<i>/wu:nd/</i>		
loss	(n)	sự mất, sự thua, sự thất bại			
<i>/lɔ s/</i>					

2. READING COMPREHENSION:

2.1 Study this diagram. Try to answer the following questions. Compare your answers with your partner.

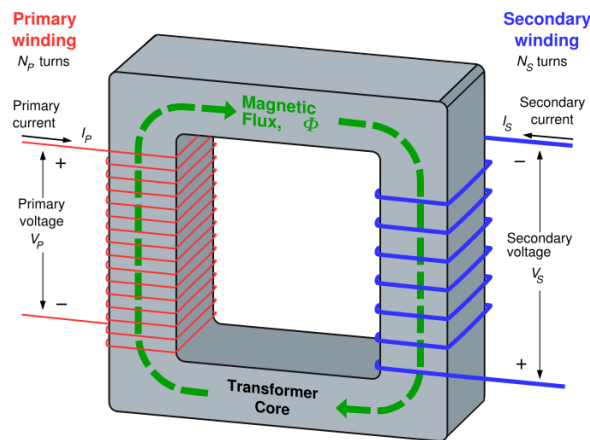

(a) What was one of the earliest uses of transformers?

1. The telephone
2. The radio
3. The television
4. The Internet

(b) What does "time-varying magnetic flux" mean?

1. A magnetic glue that is on a timer.
2. A magnetic flow that varies in the length of time.
3. A variety of currents that changes over time.
4. A timed series of magnetic conduction.

(c) Transformers can be used for huge projects, like connecting power grids, to small projects, like the transformer found in a microphone. How is this technology applicable to such diverse projects?

1. The parts used for each project are very different.
2. All operate with the same basic principles and with many similarities in their parts.
3. It is not applicable.
4. The larger systems are build on complicated extensions of the basic technology.

(d) Transformers can be used for all of the following except for

_____.

1. converting heat into electricity
2. change the AC supply frequency
3. change the voltage or current of DC
4. converting DC to AC or vice versa

2.2 Read this text to check your answers.

5 A transformer is an electrical device that transfers energy from one circuit to another by magnetic coupling with no moving parts. A transformer comprises two or more coupled windings, or a single tapped winding and, in most cases, a magnetic core to concentrate magnetic flux. An alternating current in one winding creates a time-varying magnetic flux in the core, which induces a voltage in the other windings. Transformers are used to convert between high and low voltages, to change impedance, and to provide electrical isolation between circuits.

10 The transformer is one of the simplest of electrical devices. Its basic design, materials, and principles have changed little over the last one hundred years, yet transformer designs and materials continue to be improved. Transformers are essential for high voltage power transmission, providing an economical means of transmitting power over large distances. The simplicity, reliability, and economy of conversion of
15 voltages by transformers was the principal factor in the selection of alternating current power transmission in the "War of Currents" in the late 1880's. Audio-frequency transformers, then referred to as repeating coils, were used by the earliest experimenters in the development of the telephone. While some early electronics applications of the transformer
20 have been replaced by alternative techniques, transformers are still found in many electronic devices.

25 Transformers come in a range of sizes from a thumbnail-sized coupling transformer hidden inside a stage microphone to huge gigawatt units used to interconnect large portions of national power grids. All operate with the same basic principles and with many similarities in their parts.

Transformers alone cannot do the following:

- Convert DC to AC or vice versa
- Change the voltage or current of DC
- Change the AC supply frequency.

30 However, transformers are components of the systems that perform all these functions.

3. LANGUAGE STUDY: Describing components

A transformer basically *consists of two coils* wound on a single iron core.

A transformer may be used *either to increase or decrease an applied voltage or to increase or decrease a current.*

- The following verbs can be used to break down a piece of equipment into its component parts. Note how they are used:

1. *consists of*

A *comprises* X and Y

is composed of

is made up of

2. A *contains* X and Y

includes

4. WRITING:

Transformer

A transformer is a device which changes the magnitude of an AC voltage. The transformer consists of a primary coil to which the input is applied, and a secondary coil from which the output is obtained.

- 5 The coils are insulated and wound round a former. The coils have a core of soft iron on which the former is mounted. The core is made from many thin sheets or laminations.

The sheets are oxidized so that the sheets are insulated from each other. Oxidizing the sheets reduces eddy losses.

4.1 What are the components in the diagram called?

Example: (1) is called *a core*.

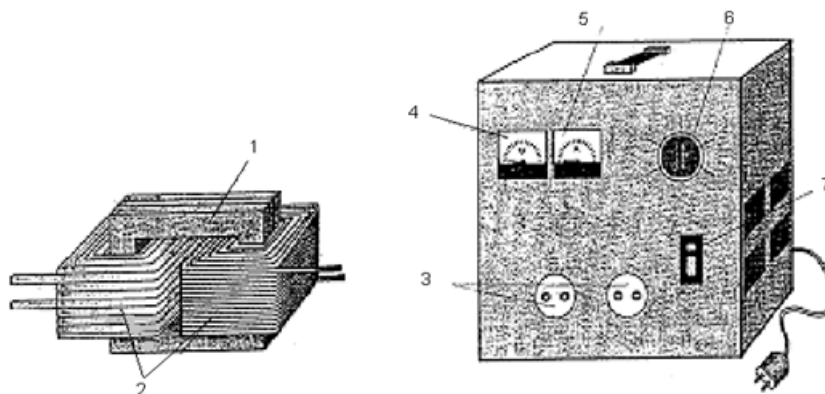

4.2 Complete the text with the help of the next diagram. Use the following words:

are made up

is placed

is composed

consists

A transformer of two coils, a primary and a secondary. The coils are wound on a former which is mounted on a core. The coils of a number of loops of wire. The core of thin pieces of soft iron. U- and T-shaped pieces are used. The former on the leg of the T.

Now label the diagram using the completed text.

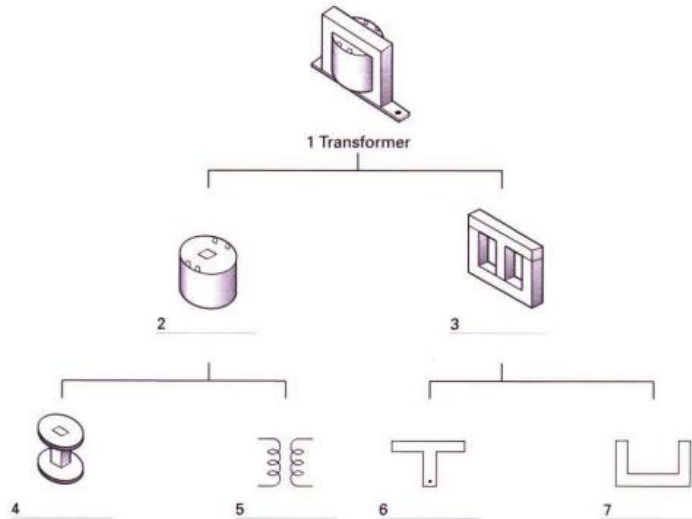

4.3 Break down each of these items into its components using the verbs you have learned. Where possible, draw a diagram to illustrate the break down.

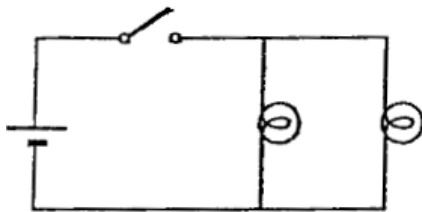

(a) a lamp circuit

.....

.....

.....

.....

.....

.....

.....

.....

.....

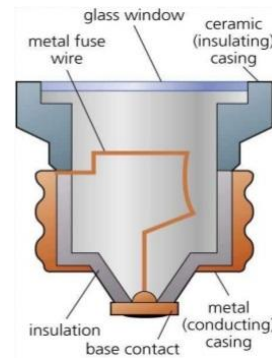

(b) a fuse

.....

.....

.....

.....

.....

.....

.....

.....

.....

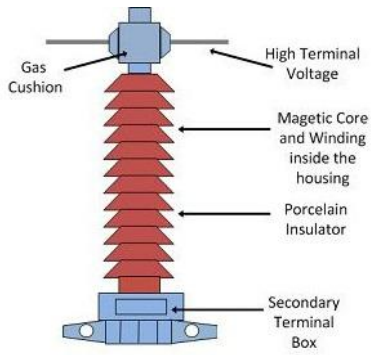

(c) a current transformer

.....

.....

.....

.....

.....

.....

.....

.....

.....

.....

.....

.....

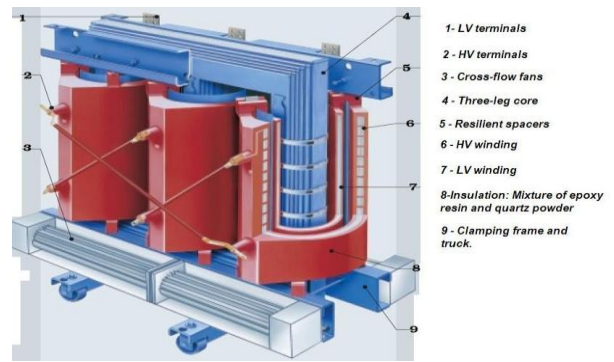

(d) a three phase voltage transformer

.....

.....

.....

.....

.....

.....

.....

.....

.....

.....

.....

.....

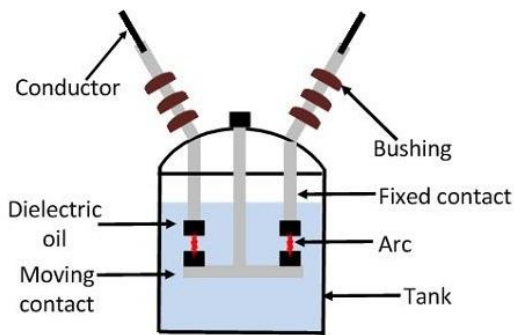

(e) an oil circuit breaker

.....

.....

.....

.....

.....

.....

.....

.....

.....

.....

.....

.....

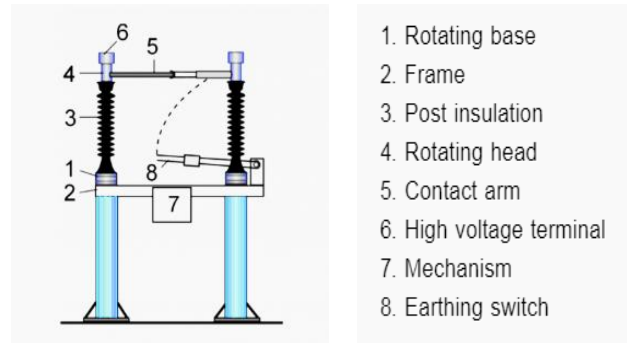

(f) an outdoor 66kV disconnector with earthing switch

.....

.....

.....

.....

.....

.....

.....

.....

.....

.....

.....

.....

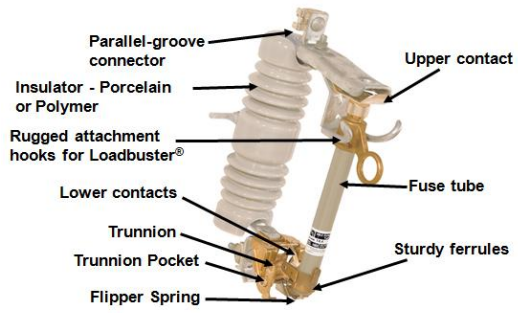

(g) an HV cutout

.....

.....

.....

.....

.....

.....

.....

.....

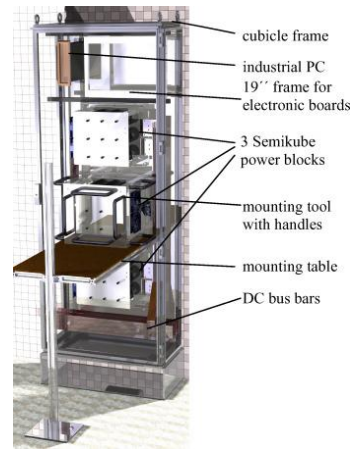

(h) an electrical cubicle

.....

.....

.....

.....

.....

.....

.....

.....

Unit 8 : Reclosers

Mục tiêu

Học xong bài học này, người học có khả năng:

- Đọc được từ vựng tiếng Anh chuyên ngành trong bài học;
- Đọc hiểu được các thông số kỹ thuật của các loại máy cắt;
- Hiểu, sử dụng được cấu trúc câu so sánh;
- Viết câu hoàn chỉnh sử dụng cấu trúc câu so sánh và tương phản;
- Đọc hiểu tài liệu liên quan đến chủ đề: Máy cắt tự đóng lại.



Nội dung

1. VOCABULARY:

ADVC	(n)	tủ điều khiển ADVC	manual /'mænjuəl/	(adj)	(thuộc) tay, làm bằng tay
aromatic /,æərə'mætik/ arrester /ə'restə/	(adj)	chất thơm	mechanism /'mekə,nizəm/	(n)	máy móc, cơ cấu, cơ chế, kỹ thuật
asymmetrical /,ei sɪ 'metrɪ k(ə)l/	(adj)	không đối xứng	momentarily /'mouməntərili/	(adv)	ngay tức khắc, trong giây lát
attempt /ə'tempt/	(n)	sự cố gắng	package /'pækɪ dʒ /	(n)	gói, bộ, khối
bracket /'brækɪt/	(n)	giá đỡ	permanent /'pə:mənənt/	(adj)	không đổi, thường xuyên
capability /,keɪpə'biliti/	(n)	khả năng, năng lực	peak /pi:k/	(n)	đỉnh cực đại, đỉnh
circuit breaker /'sə:kit'breɪkə/	(n)	cầu dao, bộ cắt mạch	plunger /'plʌ ndʒ ə/	(n)	pittông, cần đẩy, chốt đẩy
comparison /kəm'pærisn/	(n)	sự so sánh	rating plates /'reɪtɪŋ pleɪt/	(n)	thông số kỹ thuật
confine /kən'fain/	(v)	hạn chế	receiver /ri'si:və/	(n)	máy thu
construction /kən'strʌ kʃn/	(n)	sự vẽ hình, hình vẽ	recloser /ri:'klouzə/	(n)	máy cắt tự đóng lại
contactor /'kɒ ntæktə/	(n)	bộ đóng ngắt, công tắc tơ	re-energize /ri:'enə,dʒ iəz/	(v)	cấp/đóng điện lại
contrast /kən'træst/	(n)	sự trái ngược	require /ri'kwaɪə(r)/	(v)	đòi hỏi, yêu cầu
charge /tʃɑ :dʒ/	(v)	nạp điện	resin /'rezɪn/	(n)	nhựa
delay /di 'leɪ /	(v)	làm chậm trễ	rotary /'routəri/	(adj)	quay, chuyển động
detect /di 'tekt/	(v)	khám phá, dò	same /seɪm/	(adj)	giống nhau
electromechanical /i,lektroumi'kænikl/	(adj)	điện cơ	SCEM (Switch Cable Entry Module)	(n)	module chuyển đổi đầu vào cấp phía máy cắt
epoxy bushing /epɒ si 'bʊʃɪŋ/	(n)	ống cách điện bằng nhựa epoxy	stainless /'steɪnlɪs/ temporary /' tɛmpə, rəri/	(adj) (adj)	không gỉ tạm thời, nhất thời
grounding point /'graundɪŋ pɔɪnt/ impulse /'ɪmpʌ ls/	(n) (n)	điểm/ vị trí tiếp đất xung lực	transmitter /trænz'mɪtə/ trip /trɪp/	(n) (v)	máy phát ngắt, nhả

indicator /'ɪndrɪ, keɪtər/	(n) kim chỉ	vacuum interrupter /'vækjuəm ,ɪntə'rʌptə/	(n) bộ ngắt mạch chân không
initiate /ɪ'nɪʃi, eɪtɪd/	(v) bắt đầu	valve /vælv/	(n) van
interface /'ɪntəfeɪs/	(n) bề mặt chung	version /'vɜ:ʃn/	(n) phiên bản, kiểu
lid /lɪd/	(n) chụp, nắp, đầu	withstand /'wɪð'stænd/	(v) giữ vững, trụ lại

2. READING COMPREHENSION:

2.1. Fill in the gaps in the following description of the automatic recloser. Choose words from the list below:

<i>oil</i>	<i>electronics</i>	<i>distribution</i>	<i>mechanically</i>	<i>are</i>
<i>trip</i>	<i>of</i>	<i>clear</i>	<i>faults</i>	<i>actuates</i>
<i>connected</i>	<i>phases</i>	<i>temporary</i>	<i>required</i>	<i>be</i>

Automatic Circuit Recloser

Recloser is a device that is used in over head 1..... systems to interrupt the circuit to clear faults. *Automatic reclosers* have its electronic control senses and vacuum interrupters that automatically recloses to restore service if a fault is 2..... There are several attempts that may be made to clear and reenergize the circuit and if the fault still exist the recloser locks out. Reclosers are made in single-phase and three-phase versions, and use 3..... or vacuum interrupters.

Operation Systems where a *SCADA* control interface capability is 4..... in the use of automatic reclosers. The controls for the reclosers range from the original electromechanical systems to digital 5..... The operating sequence of all the reclosers can 6..... all fast, all delayed or any combination of fast followed by delayed up. Fast operations clear temporary 7..... before branch circuit line fuses are weakened. Delayed operations allow time for down time protective devices to 8..... so that permanent faults can be confined to smaller sections of the system.

A complete electronic recloser package consists 9..... the recloser which interrupts the circuit, an electronic control

which senses over-currents and 10..... the recloser and an interconnecting control cable.



Three Phase Vacuum Circuit Recloser

Tripping and Closing

25 Recloser tripping and closing 11..... initiated by signals from the electronic control. When fault currents in excess of the programmed minimum-trip value are detected in one or more 12....., a signal from the control actuates a low energy tripper in the operating mechanism of the recloser to 30 13..... the opening springs and open the interrupter contacts. Closing energy and the force required to charge the opening springs is supplied by a high-voltage closing solenoid momentarily 14..... phase-to-phase through a high-voltage contactor. At the programmed reclosing time, the control 35 energizes a rotary solenoid in the operating mechanism which 15..... closes the closing solenoid contactor to connect the closing coil to its power source. The energized closing coil pulls a plunger down, charging the opening springs.

Source: <http://www.engineermaths.com/2012/03/automatic-circuit-recloser.html>

2.2 Read the text again to answer the following questions.

a) What's the principle of operation of an automatic circuit recloser?

.....
.....

b) Describe some temporary faults?

.....
.....

c) Describe the automatic circuit recloser classifying features?

.....

.....

d) What are the advantages and disadvantages of an automatic circuit recloser?

.....

.....

.....

3. LANGUAGE STUDY: Reading ACR rating plates

Study these rating plates from two automatic circuit reclosers (ACR):

Recloser A is the U-Series ACR with ADVC Controller 15 kV.

Rated maximum voltage (15.5 kV Rating)	15.5 kV
Rated Continuous Current	630 A
Rated Frequency	50/60 Hz
Rated Mainly Active (0.7pf) Breaking Capacity	630 A
Rated Cable Charging Interrupting Current	25 A
Rated Line Charging Interrupting Current	5 A
Rated Transformer Magnetising Interrupting Current	22 A
Rated Symmetrical Interrupting Current	12.5 kA
Rated Asymmetrical Making Current (Peak)	32.5 kA
Rated Asymmetrical Making Current (RMS)	12.5 kA
Short Time Current for 3 Seconds	12.5 kA
Short Time Current Recovery Time	180 s
Rated Impulse Withstand Voltage (15.5 kV Rating)	110 kV
Power Frequency Withstand Phase/Earth and across interrupter	60 kV
Opening/Closing Mechanism	Latching magnetic actuator
D.C. Resistance Terminal/Terminal	< 120 $\mu\Omega$
Tank Construction	Stainless steel
Bushings/VI Housings	Outdoor Cyclo-Aliphatic Epoxy Resin
Maintenance Interval	5 years
Earthing	12 mm stud provided

Applicable standards	ANSI C37.60
----------------------	-------------

Recloser B is the OSM Automatic Circuit Recloser 15 kV model.

Rated maximum voltage (OSM-15-16-800) 310/312	15.5 kV
Rated Continuous Current	800 A
Fault Make Capacity RMS	16 kA
Fault Make Capacity Peak (50 Hz)	40 kA
Fault Make Capacity Peak (60 Hz)	42 kA
Fault Break Capacity	16 kA
Asymmetrical Breaking Current	17 kA
DC Component Interruption Capacity	20%
Mechanical Operations	30000
Full Load Operations	30000
Fault Break Capacity Operations	70
Short Time Current withstand 3 Seconds	16 kA
Mainly Active Breaking Capacity	800 A
Cable Charging Current	25 A
Line Charging Current	5 A
Impulse withstand across the interrupter	110 kV
Impulse withstand phase to earth and phase to phase	110 kV
Power frequency withstand phase to earth (dry) and across the interrupter	50 kV
Arc Fault Current Duration	16kA/0.2s ²
Closing Time	< 60 ms
Opening Time	< 30 ms
Interrupting Time	< 50 ms
Arcing Time	< 20 ms

Making comparisons and contrasts

- We can compare two similar features using *both*.

Example: *Both* reclosers have a rated line charging interrupting current of 5 A.

- We can contrast features which are different using *whereas*.

Example: Recloser A has a rated continuous current of 630 A, *whereas*

recloser B has a rated continuous current of 800 A.

Other words we can use for contrast are: *while, but, in contrast*. Often we can use *a comparative form of an adjective to describe a difference*.

Examples:

- + Reclose A interrupts *faster than* recloser B.
- + Recloser B is *more powerful than* recloser A.

4. WRITING:

4.1. What do the numbers in the diagrams refer to? Choose words from the list below:

a) U-Series ACR with ADVC Controller:

- | | | |
|------------------|----------------------|---------------------|
| On/off indicator | stainless steel tank | current transformer |
| control cable | vacuum interrupter | |

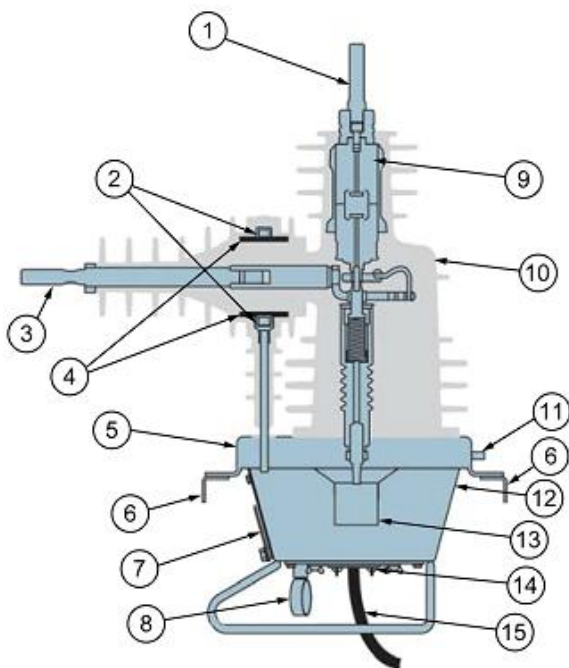

- 1 X-side terminal
- 2
- 3 I-side terminal
- 4 Capacitive voltage transformer
- 5 Stainless steel lid
- 6 Lightning arrester brackets
- 7
- 8 Manual trip ring
- 9
- 10 Epoxy bushing
- 11 Grounding point
- 12
- 13 Magnetic actuator
- 14 SCEM card
- 15

U-Series ACR Construction



ADVC Controller Components

b) OSM Automatic Circuit Recloser 15kV model:

Magnetic actuator
 auxiliary switches

opening spring
 cable connector

vacuum interrupter

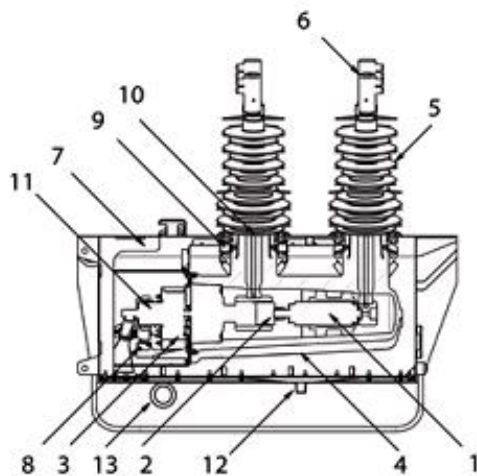

1

2 Insulated drive rod

3

4 Aromatic epoxy resin housing

5 Silicone rubber bushing boot

6

7 Stainless steel tank

8

9 Current transformer (position varies with model)

10 Capacitively coupled voltage sensor

11

12 Mechanical trip ring

Cross Section Diagram - OSM



Recloser Control (RC) Cubic

4.2 Fill in the spaces in this table using the information given on the two reclosers. In the third column indicate if the ratings listed are the *Same* or *Different*. Numbers 2 and 9 have been done for you.

	Ratings	Recloser A	Recloser B	Same/Different
1.	Rated maximum voltage			
2.	Rated Continuous Current	630 A	800 A	Different
3.	Fault Make Capacity RMS			
4.	Fault Make Capacity Peak (50 Hz)			
5.	Fault Make Capacity Peak (60 Hz)			
6.	Fault Break Capacity			
7.	Asymmetrical Breaking Current			
8.	Short Time Current withstand 3			
9.	Cable Charging Current	25 A	25 A	Same
10.	Line Charging Current			
11.	Rated Impulse Withstand			
12.	Power frequency withstand			
13.	Closing Time			
14.	Opening Time			

4.3 Making comparisons and contrast: Compare and contrast the following.

1. Valves and transistors.

.....

.....
2. Alternating and direct current.
.....
.....

3. Transmitters and receivers.
.....
.....

4. Reclosers and fuses.
.....
.....

5. Circuit breakers and reclosers.
.....
.....

Unit 9 : Safety at work

Mục tiêu

Học xong bài học này, người học có khả năng:

- Đọc được từ vựng tiếng Anh chuyên ngành điện trong bài học;
- Sử dụng câu mệnh lệnh, động từ khuyết thiếu để viết nội qui an toàn.
- Tìm hiểu về liên từ trong tiếng Anh: because of, in addition, moreover....
- Hiểu nội qui an toàn thông qua các biển báo.

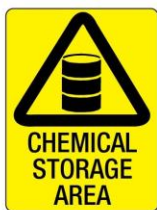

Workshop Safety Signage

- Danger & Warning Signage
- Fire Signage
- Lockout Tag Labels
- Metal & Poly Material

Nội dung

1. VOCABULARY:

adequate /'ædikwit/	(adj)	đủ, đầy đủ	lathe /leið/	(n)	máy tiện
bench /bentʃ/	(n)	bàn gia công	legal /'li:gəl/	(adj)	luật pháp
breakage	(n)	chỗ nứt, chỗ vỡ	loose-fitting	(adj)	rộng lụng thùng
/'breikidʒ /			/'lu:s,fitɪŋ/		
carelessness	(n)	sự thiếu thận trọng, sự cầu thả, sự vô ý	loss /lɒs/	(n)	sự mất, sự thiệt hại
/'keəlisnis/					
chemical /'kemɪkl/	(n)	chất hóa học	maintain	(v)	duy trì
			/meɪn'teɪn/		
claim /kleɪm/	(n,v)	đòi hỏi, yêu cầu	occur /ə'kʌ:(r)/	(v)	xảy ra
comply /kəm'plai/	(v)	tuân theo, chiếu theo	period /'piəriəd/	(n)	thời kỳ, giai đoạn
conditions	(n)	hoàn cảnh, tình thế	personnel	(n)	nhân viên, công chức
/'kən'diʃn/			/,pɜ:sə'nel/		
corrosive	(adj)	gặm mòn, phá hủy	preliminary	(adj)	mở đầu, sơ bộ

/kə'rouʃv/ cutter /'kʌ tə/	(n)	dàn máy cắt	/pri'liminəri/ prompt /prɒ mpt/	(adj)	mau lẹ, nhanh chóng
damage /'dæmɪdʒ /	(n,v)	thiệt hại, hư hỏng	properly /'prɒ pəli/	(adv)	một cách đúng đắn
discharge /dis'tʃɑ :dʒ /	(v)	đuổi ra, thải hồi	reduce /ri'dju:s/	(v)	giảm, giảm bớt, hạ
disciplinary /'disiplinəri/	(adj)	kỷ luật	refuse /ri'fju:z/	(v)	từ chối
effective /i'fektiv/	(adj)	có hiệu quả, có hiệu lực	requirement /'ri:kwaɪəmənt/	(n)	nhu cầu, yêu cầu, luật lệ
employee /,ɪmplɔ 'i:i:/	(n)	người lao động	result /ri'zʌ lt/	(v)	dẫn đến, đưa đến
ensure /in'ʃuə/	(v)	bảo đảm	rule /ru:l/	(n)	nguyên tắc
even /'i:vn/	(adj)	bằng phẳng, tron tru	separately /'seprətli/	(adv)	tách biệt nhau
flammable /'flæməbl/	(adj)	dễ cháy	shift /ʃift/	(n)	ca. kíp
forget /fə'get/	(v)	quên	statement /'steɪtmənt/	(n)	sự bày tỏ, sự trình bày, sự phát biểu
grinder /'graɪndə/	(n)	máy mài	subject /'sʌ bʒ ikt/	(v)	bắt phải chịu
harmful /'hɑ :mful/	(adj)	gây hại, có hại	submit /səb'mɪt/	(v)	trình, đệ trình
hazard /'hæzəd/	(n)	mối nguy hiểm, rủi ro	supervision /,su:pə'vɪʒ n/	(n)	sự trông nom, sự giám sát
immediate /i'mi:dʒət/	(adj)	trực tiếp	toxic /'tɒ ksɪk/	(adj)	độc
injure /'ɪndʒ ə/	(v)	làm tổn thương	witness /'wɪtnɪs/	(n)	lời chứng, nhân chứng
investigation /ɪn,vesti'geɪʃn/	(n)	sự điều tra			

2. READING COMPREHENSION [1]:

2.1 What do these warning labels on chemicals mean? Match each label to the correct warning.

- | | |
|----------------------|---------------|
| (a) Highly flammable | (d) Corrosive |
| (b) Harmful | (e) Oxidizing |
| (c) Explosive | (f) Toxic |

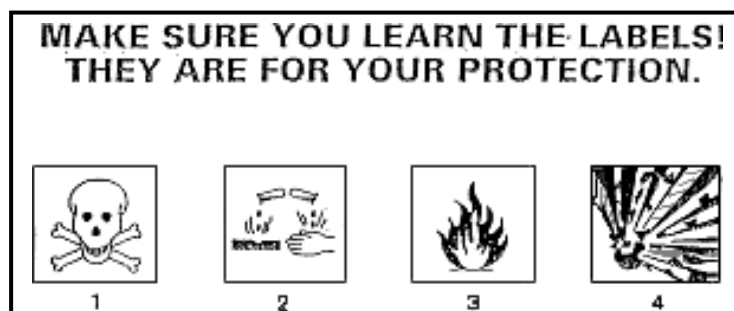

2.2 Study the safety instructions from a work below, and then answer these questions.

- (a) Who are the instructions for?
- (b) Who wrote them?
- (c) What was the writer's purpose?

- 1 Wear protective clothing at all times.
- 2 Always wear eye protection when operating lathes, cutters, and grinders and ensure the guard is in place.
- 3 Keep your workplace tidy.
- 4 The areas between benches and around machines must be kept clear.
- 5 Tools should be put away when not in use and any breakages and looses reported.
- 6 Machines should be cleaned after use.

3. LANGUAGE STUDY: Making safety rules

3.1 What are the differences in meaning, if any, between these statements?

- 1 Wear protective clothing.
- 2 Always wear protective clothing.
- 3 Protective clothing must be worn.

We can make safety rules in these ways:

- 1 Using an imperative:

Wear protective clothing.

Do not wear loose-fitting clothing.

2 *Always/never* are used to emphasize that the rule holds in all cases.

Always wear protective clothing.

Never wear loose-fitting clothing.

3 We can use a modal verb for emphasis.

*Protective clothing **must be worn**.*

*Protective clothing **should be worn**.*

3.2 Study this list of unsafe environmental conditions (hazards).

Write safety rules to limit these hazards using the methods given above. For example:

inadequate lighting → *Lighting must be adequate, or
Lighting should be adequate.*

(a) uneven floors

.....
.....

(b) unguarded machinery

.....
.....

(c) untidy workbenches

.....
.....

(d) untidy workplace

.....
.....

(e) badly maintained machinery

.....

.....
(f) carelessly stored dangerous materials
.....

.....
(g) inadequate ventilation
.....

.....
(h) damaged tools and equipment
.....

.....
(i) machinery in poor condition
.....

.....
(j) equipment used improperly
.....

.....
(k) equipment operated by untrained personnel
.....

.....
(l) apprentices working without supervision
.....

4. WRITING: Ways of linking ideas

4.1 In order to make our writing effective, we have to make sure our readers can follow our ideas. We have to learn how to mark reasons, results, and contrasts in our writing.

Example 1: What are the links between these ideas? What words can we use to mark the links?

- (1) The accident happened.
- (2) The operator's carelessness.
- (3) The supervisor was not present.

- Sentence 2 is a *reason* for sentence 1. Sentence 3 is an *additional* reason.
We can mark the link between them like this:

*The accident happened **because of** the operator's carelessness. **In addition / Moreover**, the supervisor was not present.*

- We use *because of* to introduce a reason which is a noun or a noun phrase.
We use *in addition* and *moreover* to introduce an additional reason.

Example 2: What are the links between these ideas? What words can we use to mark the links?

(4) Suitable protection should be worn.

(5) Safety helmets should be used where there is a danger of falling objects.

- Sentence 5 is an *example* to illustrate sentence 4. We can mark this in this way:

*Suitable protection should be worn. **For example / For instance**, safety helmets should be used where there is a danger of falling objects.*

4.2 Show the links between these sets of ideas using appropriate linking words from this unit.

(a) Many accidents happen.

Workers' carelessness.

.....

(b) Education can reduce accidents.

It is important that all workers receive training in basic safety.

.....

.....

(c) Eye injuries can be serious.

Goggles must be worn for grinding and cutting.

.....

.....

(d) Safety gloves provide protection for the hands.

They prevent burns.

They reduce the danger of cuts.

.....

.....

.....
(e) Safety shoes protect the feet against falling objects.
They prevent the feet getting caught in machinery.
.....
.....

(f) Respirators should be worn in dusty conditions.
Dust can damage the lungs.
.....
.....

(g) Safety gear exists for every danger.
Each year people are injured.
They refuse or forget to wear the right gear.
.....
.....
.....

5. READING COMPREHENSION [2]:

Knowing what the writer's purpose is, who the writer is, and who the intended readers are, can help us to understand a text. The safety instructions in Part 1.3 are clearly intended to encourage employees to be safety conscious and reduce the risk of accidents. The writer is perhaps a supervisor or the company safety officer, and the intended readers are machine operatives. Knowing these things can help us to work out the meaning of any part of the text we may not understand.

5.1 Study the company document on safety on the next page, and then answer these questions:

- (1) Who is this document for?
 - a machine operatives
 - b managers
 - c all employees
 - d injured employees
- (2) Who wrote this document?
 - a trade union representative
 - b technician
 - c manager
 - d medical staff
- (3) What is the writer's intention?
 - a to prevent accidents
 - b to ensure speedy help for injured employees
 - c to protect the company
 - d to warn about dangers

Accident investigation

Whenever an accident occurs that results in an injury (medical case), damage of equipment and material, or both, prompt accident investigation by the immediate manager is required. A written preliminary investigation will be completed by the end of the particular shift or business day on which the accident occurred.

In no event should there be a delay of more than 24 hours. Failure to comply with this requirement may subject the immediate manager to disciplinary action up to and including discharge.

Without adequate accident investigation data the Company may be

subjected to costs, claims, and legal action for which it has no defence.

As a minimum, the preliminary accident investigation report will include the following:

- (1) Name, occupation, and sex of injured worker.
- (2) Place and date/time of accident.
- (3) Description of how the accident happened.
- (4) Immediate causes of the accident - unsafe acts and unsafe conditions.
- (5) Contributing causes - manager safety performance, level of worker training, inadequate job procedure, poor protective maintenance, etc.
- (6) Witness(es) - name and department.
- (7) Corrective action taken - when.

The employee who was injured and any employee(s) who witnessed the incident should be separately interviewed as soon as possible. A copy of the report must be submitted to the Manager - Human Resources for review. Another copy of the report is to be retained for a period of not less than the injured employee's length of employment plus five (5) years.

5.2 Study this brief report of an accident. In which points does it not meet company policy on reporting accidents?

To:	Name Manager	Department & Location Human Resources	Date 17 May
From:	Name D. Taylor	Department & Location Mech. Eng. Workshop	Tel. 6200
Subject:	Preliminary Report, Accident, 12 May		

	While turning a brass component on Tuesday, last week, Kenneth Oliver, machinist, received an injury to his eye. He was taken to the Eye Hospital where I understand he was operated on. I believe the accident was due to carelessness.
--	--

TÓM TẮT NGỮ PHÁP

UNIT 1: Wh-questions

- | | |
|---|---|
| 1. What is this? | - This is a base/ guard/ blade/ plug/ wire. |
| = What's it (this) called in English? | - It's called a socket/ cable. |
| 2. Where is it? Where is the screwdriver? | - It's on the table. |
| fan? | under the table. |
| guard? | in the box. |
| socket? | beside the window. |

- | | | |
|----|--|-------------------------------------|
| | switch? | below the table. |
| 3. | How high is the fan? | - It's forty-five centimetres high. |
| | How long is the wire? | - It's ten metres long. |
| | How long is the wall? | - The wall is four metres long. |
| 4. | What's wrong? - The wall is ten metres long, but the wire is only eight metres long. | |
| 5. | What shape is it? | - The door is rectangular. |
| | | - The plug is triangular. |
| | | - The window is square. |
| | | - The guard is circular. |
| | | - The socket is round. |

UNIT 2: Adverbs "clockwise, backwards, to the right..."

1. Check that the switches are on. - Yes, they are on, Alan.
2. Move it forwards.
Move the car forwards.
Bend the hook inwards.
3. They have no cover.
This fan is dangerous. It has no cover.
These switches are dangerous. They have no covers.

UNIT 3: Sequence words and Verbs "switch, press, push..."

1. First, you mark the hole!
2. Switch off before you touch the wire!
3. The current is stopped by pressing this switch.

UNIT 4: Modal verbs and Relative clause

1. You might get a shock.
2. You must never smoke near petrol.
3. You should not use a dirty saw.
4. Tools that are damaged and dangerous.

UNIT 5: Describing function and purpose

1. What does the fuse do? - It protects a circuit.
= The function of a fuse is to protect a circuit.
2. What is an ammeter for? - It is for measuring current.

- = + It is used for measuring current.
- + It is used to measure current.
- + We measure current with an ammeter.
- + We measure current using an ammeter.

UNIT 6: Describing components

1. dismantle a piece of equipment into its main parts.
consists of/ is made up of/ is composed of
2. name components:
known as/ called
3. locate components:
is placed between
4. connect components:
is connected to

UNIT 7: Describing components (cont)

1. *consists of/ comprises / is composed of/ is made up of*
2. *contains/ includes*

UNIT 8: Making comparisons and contrasts

- 1 Reading ACR rating plates:
2. Making comparisons and contrasts
 - Both* reclosers have a rated line charging interrupting current of 5 A.
 - Recloser A has a rated continuous current of 630 A, *whereas* recloser B has a rated continuous current of 800 A.
 - Reclose A interrupts *faster than* recloser B.
 - Recloser B is *more powerful than* recloser A.

UNIT 9: Making safety rules and Conjunctions

- 1 - Using an imperative:
 - Wear protective clothing.*
 - Do not wear loose-fitting clothing.*
- *Always/never* are used to emphasize that the rule holds in all cases.
 - Always wear protective clothing.*
 - Never wear loose-fitting clothing.*

- We can use a modal verb for emphasis.

Protective clothing must be worn.

Protective clothing should be worn.

2. - The accident happened. The operator's carelessness. The supervisor was not present.

→ The accident happened because of the operator's carelessness. In addition, the supervisor was not present.

TÀI LIỆU THAM KHẢO

- *English for Technical Students*; Longman – David Bonamy.
- *Oxford English for Electrical and Mechanical Engineering*; Oxford University Press, 1995 - Eric H.Glendinning, Norman Glendinning.
- *Oxford Advanced Learner's Dictionary of current* - AS.Hornby.
- *Oxford English for Electronics*; Oxford University Press, 1993 - Eric H.Glendinning, John Mc Evan.
- *English for Science*, Prentice Hall Regents, Englewood Cliffs, New Jersey, 1989.
- *Giáo trình Tiếng Anh chuyên ngành điện*, NXB Hà Nội 2007 - Sở Giáo dục và Đào tạo Hà Nội - Hứa Thị Mai Hoa.
- *Catalogue*, Dong Anh electrical equipment corporation, Electrical equipment designing and manufacturing co.,Ltd.
- *OSM, User Manual, OSM Automatic Circuit Recloser 15kV, 27kV & 38kV models 2018*, Noja Power.
- *U-series ACR with ADVC Controller, Installation-Operation and Maintenance Manual 2017*, Schneider Electric.